

EVOSET

PWB+

TOOL MASTER Basic

EyeRay®

MANUAL

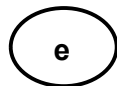

Neither all nor part of this documentation may be reproduced, communicated to third parties, stored in a database system or translated into another language without the written permission of Evoset AG.

Steg, December 2023

Valid from software version: V.3.12.0.0

EVOSSET

The information contained in this document cannot be modified without prior notice. Evoset AG therefore accepts no liability.

Evoset AG declines all guarantees and any legal liability or liability for consequential damages arising out of or in connection with the content or use of this manual.

Furthermore, Evoset AG declines all guarantees and any legal liability or liability for consequential damages arising from the improper use of the hardware and/or software.

The equipment layout or design is subject to change without notice. Evoset AG therefore accepts no liability.

All other trademarks and product names used in this manual are the property of their respective companies and manufacturers.

Evoset AG waives all rights of ownership regarding trademarks and product names that are not its property.

Table of contents

1 INSTRUMENT DESCRIPTION	4
1.1 FRONT VIEW.....	4
2 INSTALLING THE DEVICE	5
2.1 PACKING LIST.....	5
2.2 UNPACKING AND REASSEMBLY.....	6
3 UNIT OPERATION	8
3.1 MOVING THE AXES.....	8
3.2 SPINDLE TYPES.....	9
3.3 STARTING UP THE UNIT AND THE HP MINI PC.....	9
4 EYERAY® IMAGING SYSTEM	10
4.1 LOGIN SCREEN.....	10
4.2 START EYERAY® AND OPEN A SESSION.....	11
4.2.1 <i>Closing EyeRay® and changing session</i>	12
4.2.2 <i>Open LogMeIn123 remote online maintenance</i>	13
4.2.3 <i>Standard unit calibration</i>	14
4.3 EYERAY® SCREEN ILLUSTRATION.....	15
4.4 MENU STRUCTURE.....	16
4.5 BASIC SETTINGS.....	17
4.5.1 <i>Lighting</i>	17
4.5.2 <i>Align camera</i>	18
4.5.3 <i>Parallelism correction</i>	19
4.5.4 <i>Absolute point zero / Calibration</i>	20
4.5.5 <i>Camera pixel adjustment</i>	21
4.5.6 <i>Parameters</i>	22
4.6 SHORT CUTS.....	26
4.6.1 <i>Create short cuts</i>	26
4.6.2 <i>Deleting short cuts</i>	27
4.7 MEASUREMENT.....	28
4.7.1 <i>Focus indicator bar</i>	28
4.7.2 <i>Selecting a reference point</i>	29
4.7.3 <i>Select a measurement function (MF)</i>	31
4.7.4 <i>Measurement function descriptions</i>	32
4.7.5 <i>Select a measurement method</i>	37
4.7.6 <i>Measurement method descriptions</i>	37
4.7.7 <i>Select the axis measurement/counter display mode</i>	54
4.8 PRINTING THE MEASURED VALUES.....	56
4.8.1 <i>Printing standard labels</i>	56
4.8.2 <i>EyeRay® custom label printing, option</i>	56
4.8.3 <i>EyeRay® report printing, option</i>	56
4.8.4 <i>Changing label size</i>	57
4.9 DATA TRANSFER.....	58
4.9.1 <i>List of tools</i>	58
4.9.2 <i>Open a PDF file</i>	62
4.9.3 <i>Post Processors</i>	63
4.9.4 <i>Balluff chip read/write system</i>	64
4.10 DATABASE.....	67
4.10.1 <i>Reference point database</i>	67
4.10.2 <i>Backup and restore</i>	71

5	OPTIONAL FUNCTIONS	73
5.1	KV SPINDLE OPERATION.....	73
5.2	PRINT A REPORT (SOFTWARE OPTION).....	73
5.3	EYERAY® CUSTOM LABEL PRINT (SOFTWARE OPTION)	74
5.4	EYERAY® POSTPRO DATA TRANSFER (SOFTWARE OPTION)	74
5.5	RFID CHIP/EYERAY® DATA TRANSFER (SOFTWARE OPTION).....	74
5.6	CENTRE HEIGHT MEASUREMENT WITH CAMERA/EYERAY® (OPTION)	74
5.7	EYERAY® TOOL MANAGEMENT (OPTION FOR SW).....	74
5.8	CUSTOM MEASUREMENT FUNCTION (SOFTWARE OPTION)	74
5.9	EXCEL AND EYERAY® LINK (SOFTWARE OPTION)	74
6	SOLUTION	74
7	DIAGRAMS	79
7.1	OVERVIEW OF THE TM QUADRA CONNECTIONS	79
7.2	USB HUB/NEEDLE BEARING CONNECTION	80
7.3	USB HUB/KV SPINDLE CONNECTOR	81
7.4	PNEUMATIC CONNECTIONS	82
7.4.1	<i>Tool ring: Needle roller bearing</i>	82
7.4.2	<i>Tool ring: KV spindle</i>	83
8	DECLARATION OF CONFORMITY.....	84

1 Instrument description

1.1 Front view

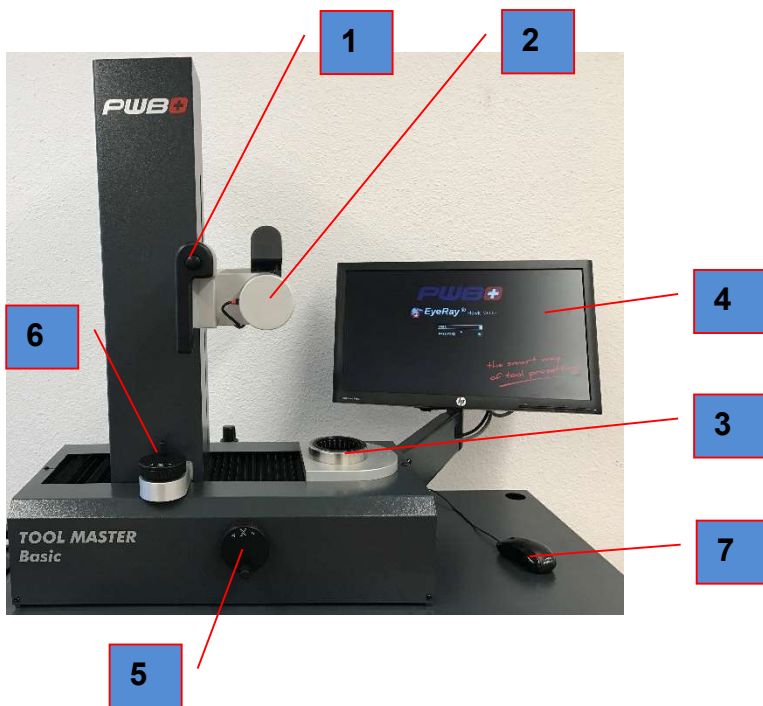

Rear view

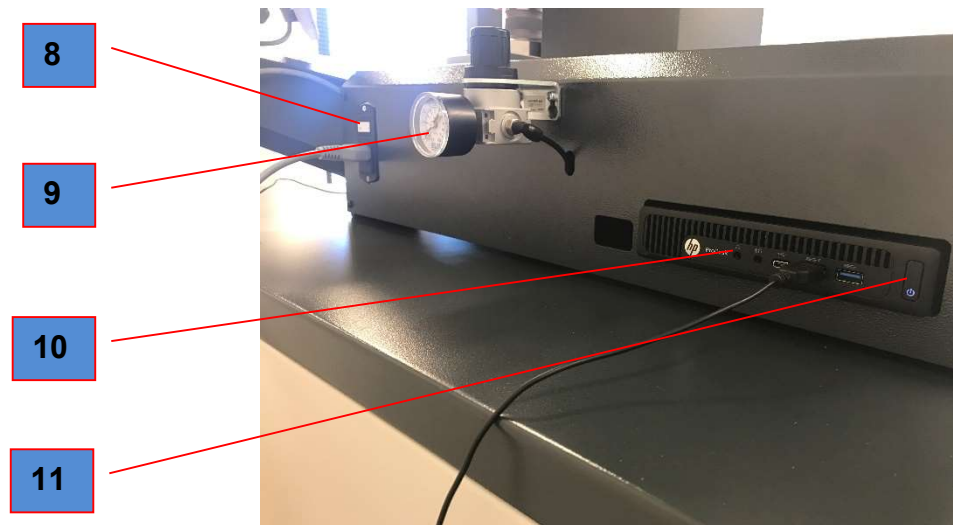

1. Handle to lock/unlock and move both axes
2. Camera
3. Tool spindle
4. HP monitor (no touch)
5. X-axis fine adjustment wheel
6. Y-axis fine adjustment wheel
7. Mouse
8. on/off (230V)
9. Air supply unit
10. HP ProDesk 600 G2 DM i3-6100 3.20Ghz
11. Switch the PC on and off

2 Installing the device

2.1 Packing list



IMPORTANT: If the device has been stored at a temperature below 5°C, wait a few hours before unpacking it to prevent condensation forming on the parts. Condensation can damage the sensitive parts of the device. Set aside the original packaging

2.2 Unpacking and reassembly

Note that 2 people are required for this operation!

The unit is delivered in a wooden crate.
The Tool Master is fixed to the pallet.
The accessories are placed in the crate

- 1.) Remove the top of the wooden crate and remove the accessories.
- 2.) Remove the sides of the wooden crate.
- 3.) Lift the presetter (2 people are needed) and place it on a workbench.



The unit is fixed to the bottom plate using 4 screws and transport brackets.

- 4.) Fix the air supply unit to the back of the unit and connect it to the compressed air supply (5 to 6 bars, degreased, dry air).

Air supply unit

Compressed air,
pressure: 5 to 6 bars



- 5.) Remove the screw that secured the Z axis during transport: the screw is located at the back of the column.
The X axis is fixed using an angle bracket fitted on the base plate (see arrow =>).
Release the bellows and move it to the back.
Unscrew the angle bracket screws and then remove it.
Refit the bellows in their intended position.

Z axis transport lock

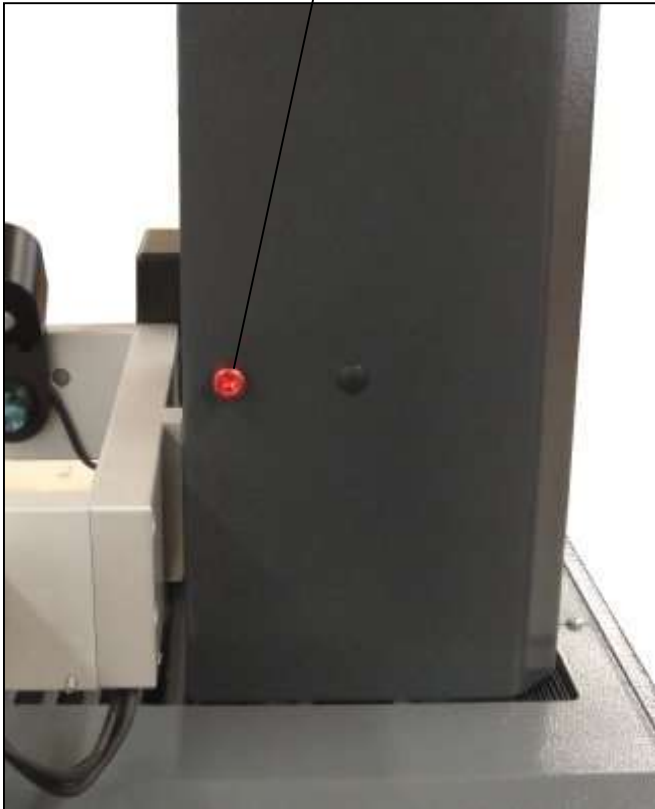

X axis transport lock

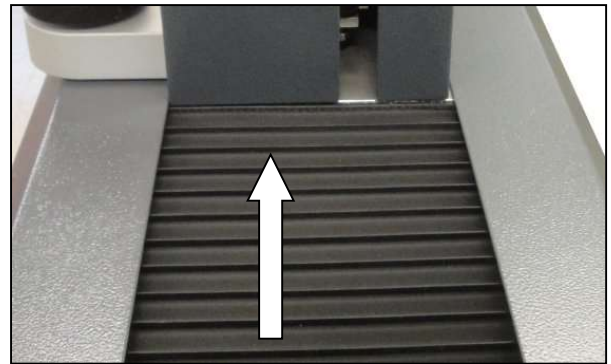
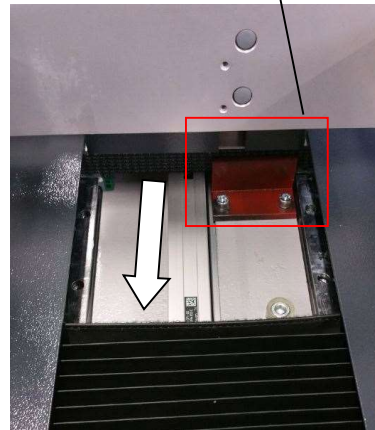

3 Unit operation

3.1 Moving the axes

The two axes will be locked as soon as the unit is connected to the compressed air

Quick movement:

Press the button on the black handle to release the axis, and move the carriage/camera to the required position.



Fine adjustment:

Release the button on the handle and use the "X" and "Z" adjustment buttons to move the axes to the nearest micron.

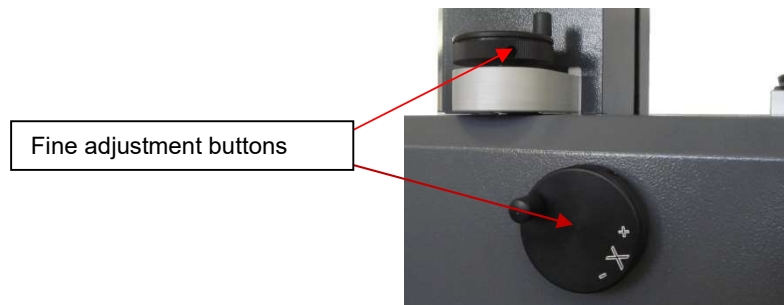

3.2 Spindle types

The TM Quadra is available with 2 types of spindle.

Needle bearing spindle (standard)
Available sizes: ISO40 and ISO50

KV spindle (optional)
Available sizes: ISO50

3.2.1 "Needle bearing" spindle

- Minimum wear, prevents damage to the tool cones
- Better locating than with a full contact surface
- Oil and dirt remain in the cavities and have no effect on measurement accuracy
- Easy cleaning/no maintenance costs
- Stable runout

3.2.2 KV spindle

The KV spindle functions can be controlled by the EyeRay® software.

- High-precision preloaded parts
- Pneumatic circular clamping/vacuum clamping/pneumatic bearing block functions
- See section **5.1 KV spindle operation** for more information

3.3 Starting up the unit and the HP mini PC

Device main power supply switch

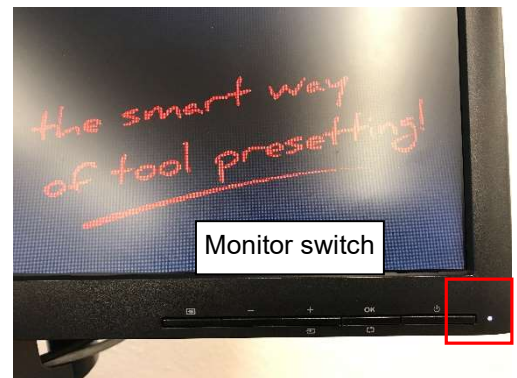

Mini PC main switch



4 EyeRay® imaging system

4.1 Login screen



Note: When starting up the unit, make sure there are no USB thumb drives or other devices connected to the all-in-one Shuttle PC. The unit would not start up correctly.

The following screen is displayed when the PC is ready:



Icons:



To stop
the PC



To restart the PC

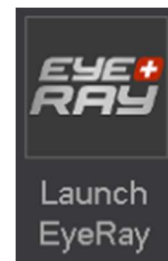

To launch the
EyeRay®
software

4.2 Start EyeRay® and open a session

Click the "Launch EyeRay" icon

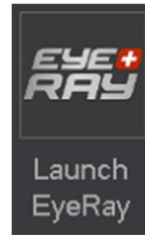

The software launches and opens the session login window:

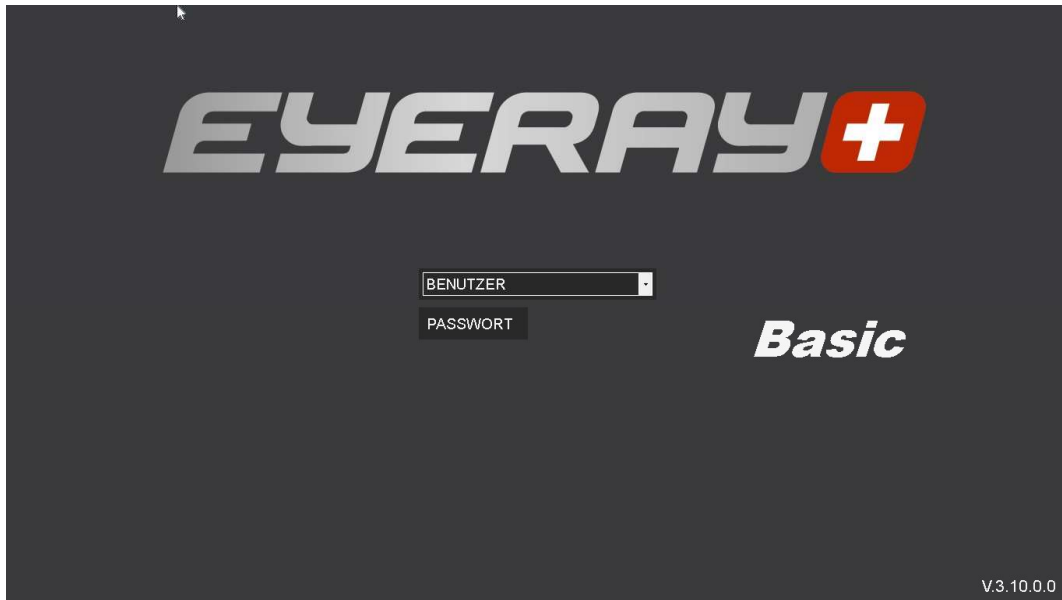

Click the arrow next to the user input field.
A list of defined users will be displayed.

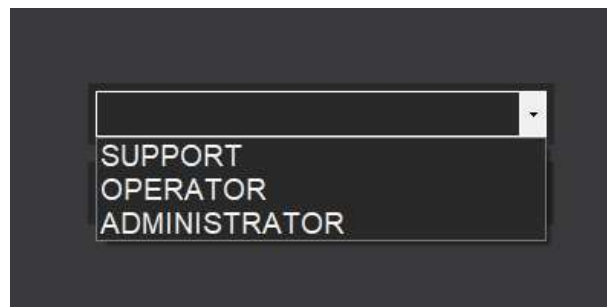

Selection:

User ID ADMINISTRATOR
Password admin

User ID OPERATOR
Password pwb

User ID: **SUPPORT (for online support only)**
Password: ----

Confirm with:

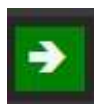

4.2.1 Closing EyeRay® and changing session

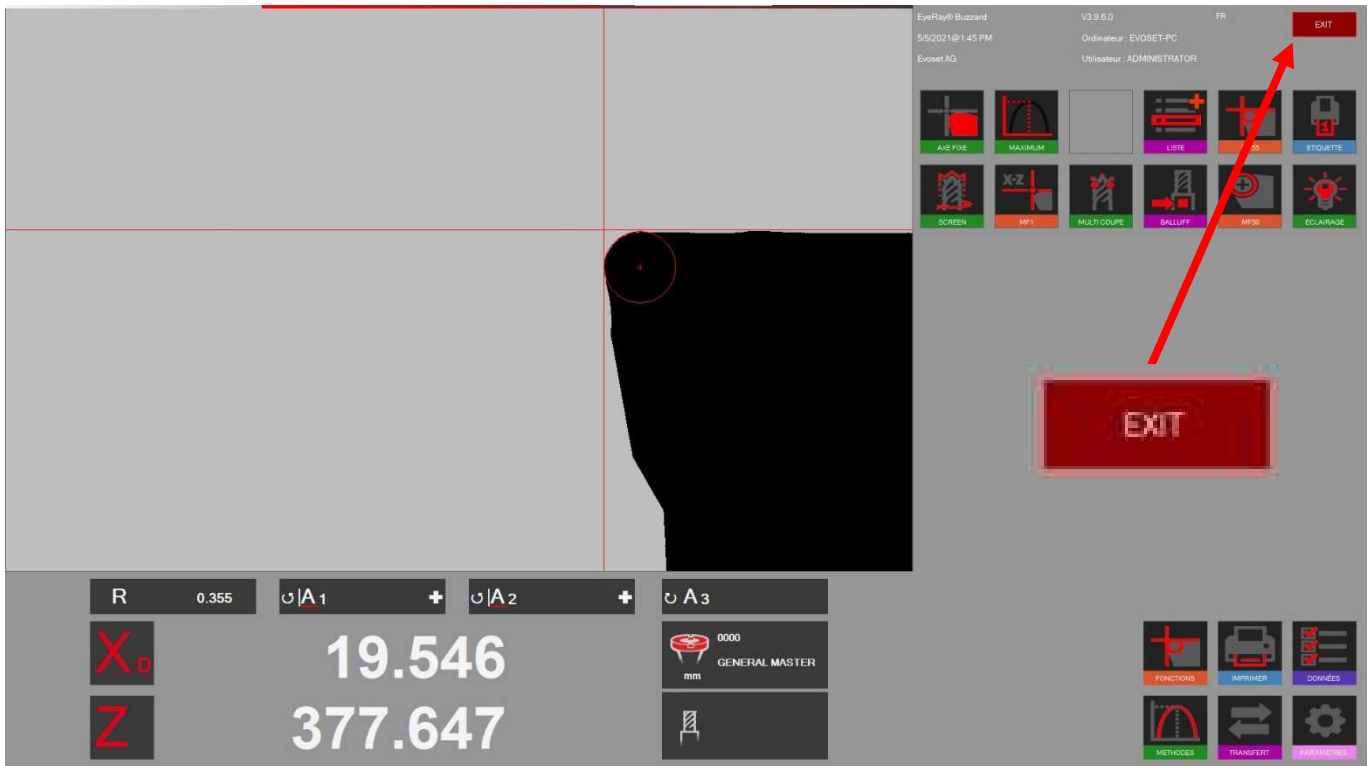

Click button

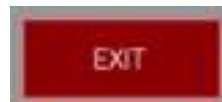

Several options are then displayed:

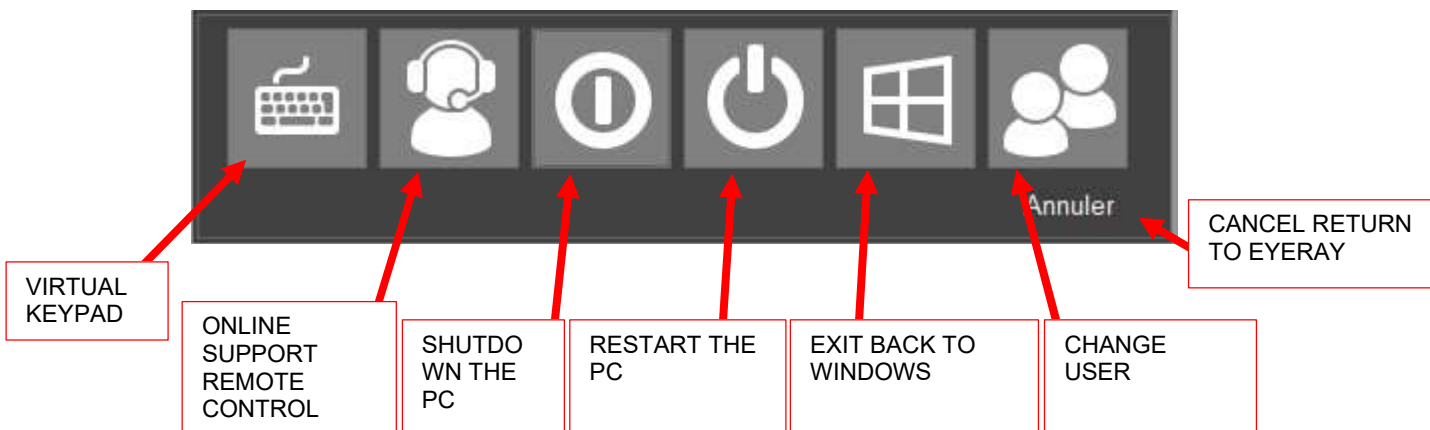

4.2.2 Open LogMeIn123 remote online maintenance



Click the support icon, LogmeIn123 will launch

There are 2 ways to get started:



1- Using a six-digit code supplied by the after-sales service



2- By sending a request directly from the software interface



4.2.3 Standard unit calibration

EyeRay® starts and the calibration window appears.

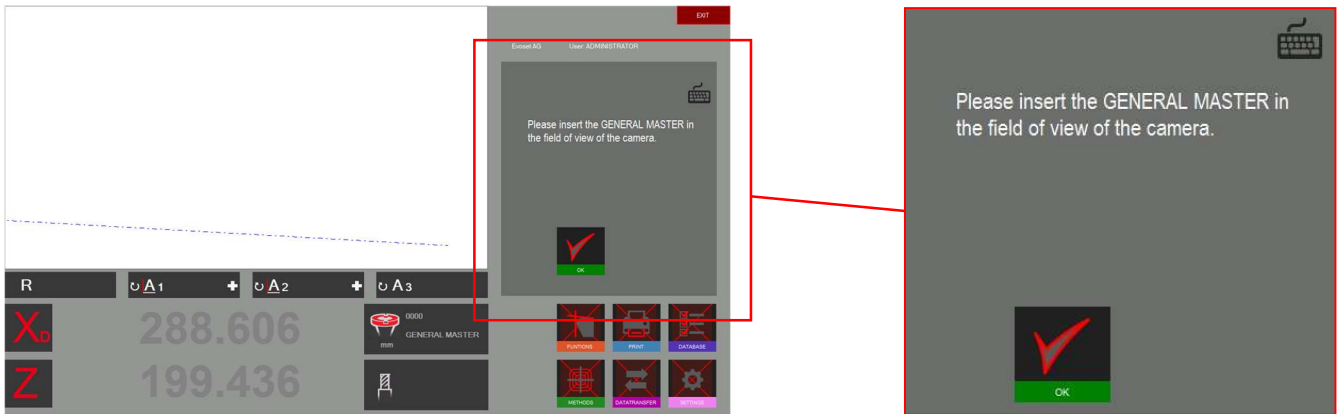

Place the master mandrel in the spindle and position it in the camera's field of vision.



Confirm with:

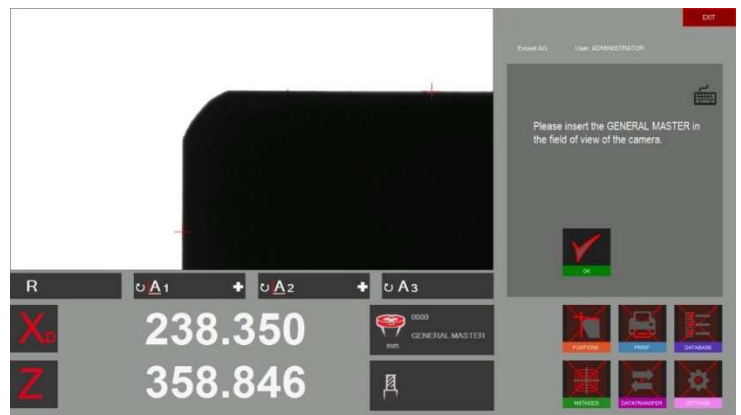

After confirmation, the message that appears shows the master mandrel values.

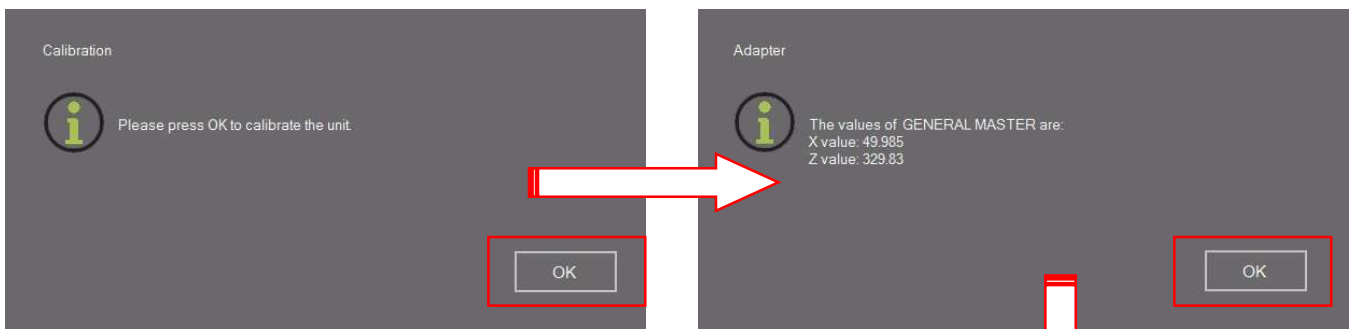

Confirm the values with "OK" => EyeRay® completes the calibration.

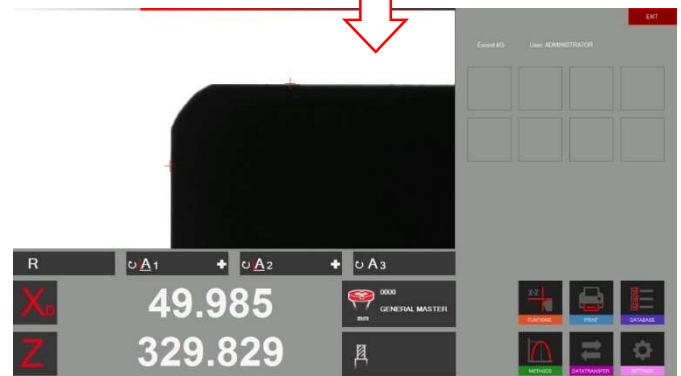

4.3 EyeRay® screen illustration

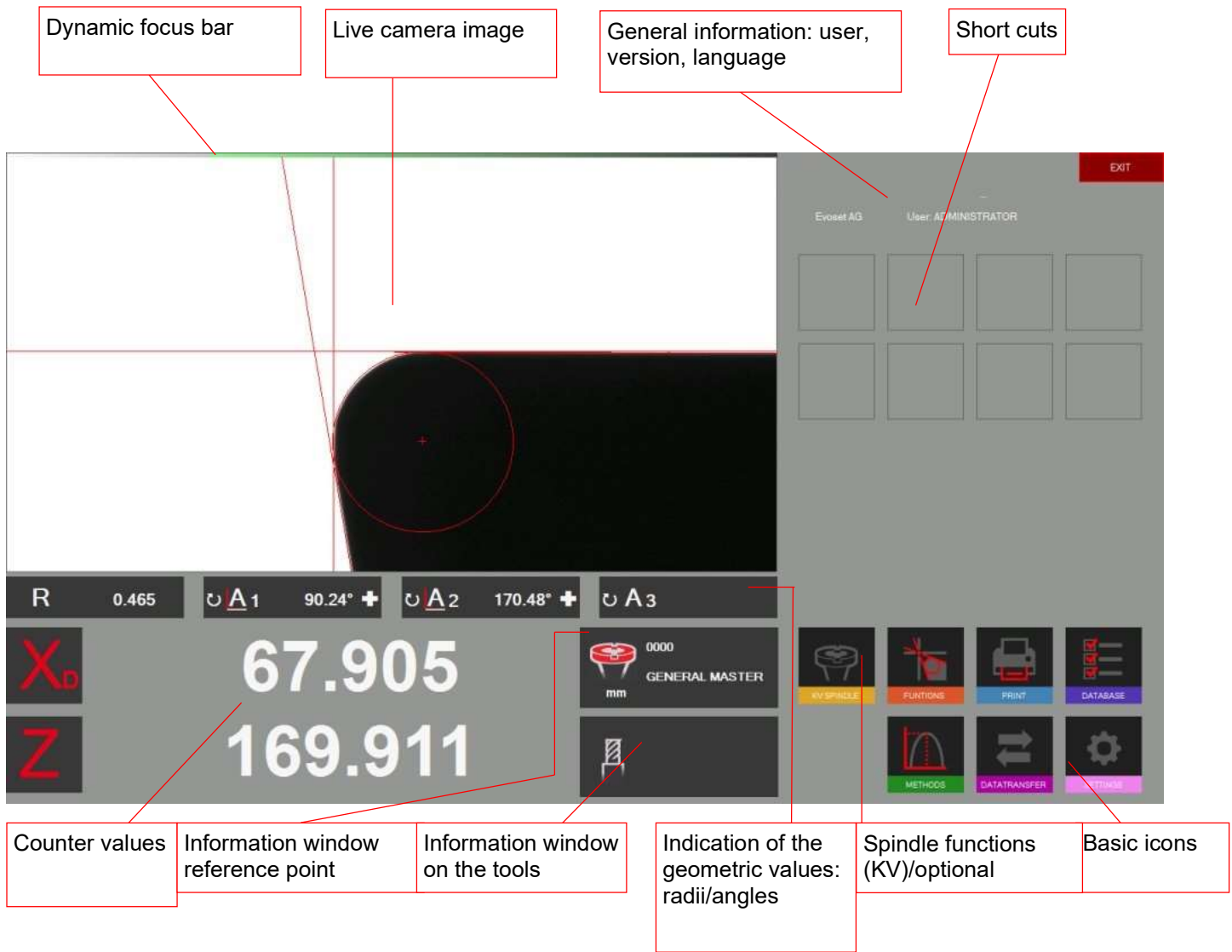









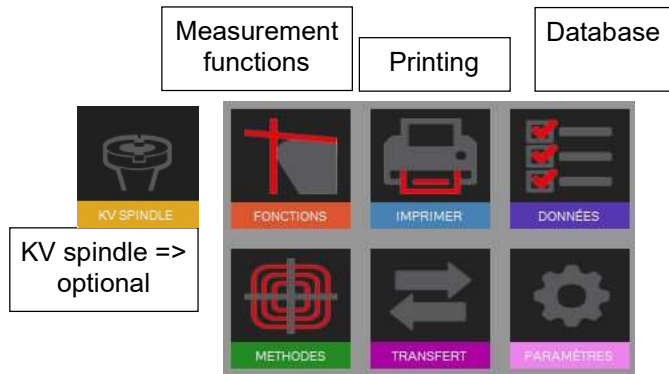

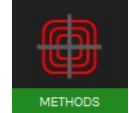





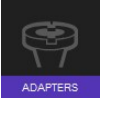







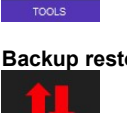





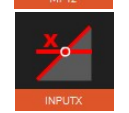
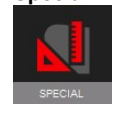

EyeRay® => Easy to use:

Run the software using only the basic icons

4.4 Menu structure

Activate all sub-menus using the 6 basic icons:

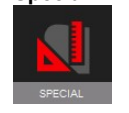
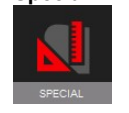
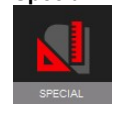

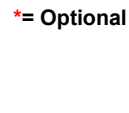
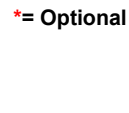
Methods	Functions	Print	Configuration	Data	Transfer			
 METHODS	 FONCTIONS	 PRINT	 SETTINGS	 DATABASE	 DATATRANSFER			
<p>Maximum</p>  MAXIMUM	 MF1	<p>Format 1 label</p>  LABEL	<p>Lighting</p>  LIGHT	<p>Reference point</p>  ADAPTERS	<p>Measurement list</p>  LISTE			
<p>Setting</p>  PRESET		<p>Format 2 label*</p>  LABEL				<p>Camera alignment</p>  CAM PARALLELITY	<p>Tool Management</p>  TOOLS	<p>Open PDF</p>  OPEN PDF
<p>Screen</p>  SCREEN		<p>Report*</p>  REPORT				<p>Pixel size</p>  SET PIXEL	<p>Backup restore</p>  BACKUP	<p>PostPro gauges*</p>  POST PROC.
<p>Multi-cutter</p>  MULTICUTTING		<p>MF3</p>  MF3				<p>Parallelism corr.</p>  PAR. COMP.	<p>Balluff chips*</p>  BALLUFF	
<p>Front light</p>  FRONT LIGHT		<p>M4</p>  M4				<p>Calibration</p>  SET ZERO	<p>Parameters</p>  PARAMETERS	
<p>Fixed Axes</p>  FIXED AXIS		<p>MF12</p>  MF12				<p>MF advance*</p>  ADVANCE	<p>User/MF*</p>  USERS	
<p>Centre point</p>  POINT		<p>INPUTX</p>  INPUTX				<p>Special MF*</p>  SPECIAL	<p>Special MF*</p>  SPECIAL	
<p>Theoretical Angle/ Radius</p>  THEO. RADIUS		<p>RUNDOUT</p>  RUNDOUT				<p>MF advance*</p>  ADVANCE	<p>User/MF*</p>  USERS	
<p>Measurement point</p>  P. MEASURE		<p>Special MF*</p>  SPECIAL				<p>Special MF*</p>  SPECIAL	<p>Special MF*</p>  SPECIAL	
<p>Fixed Point</p>  FIXED POINT		<p>Special MF*</p>  SPECIAL				<p>Special MF*</p>  SPECIAL	<p>Special MF*</p>  SPECIAL	

4.5 Basic settings



Click this icon to display the menu with the 5 basic settings

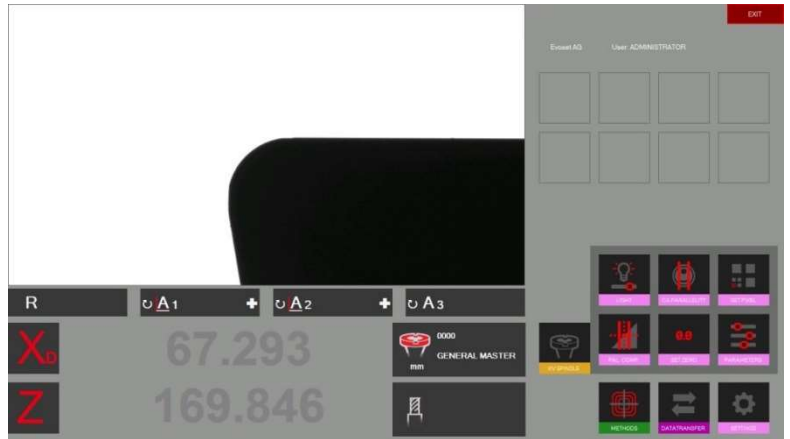
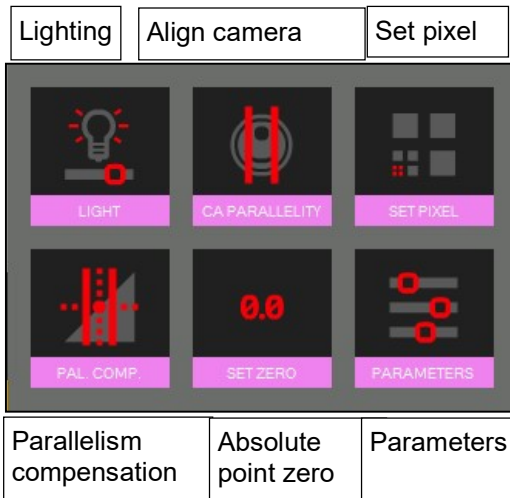

4.5.1 Lighting

Open the basic settings using the icon



Use this icon to check and adjust the lighting intensity

The horizontal lines indicate the light intensity at the top, centre and bottom of the live image.

The vertical lines indicate the light intensity at the right, centre and left of the live image

All the horizontal lines must be within the tolerances.

All the vertical lines must be within the tolerances

To improve the light intensity:

- Clean the camera lens
- Clean the lighting lens

If the light intensity is still not sufficient, use the "+" icon to increase it until the lines are within the field tolerance limits.

Confirm with



Check the lighting regularly => at least once a week, or more if the light around the unit is changing.

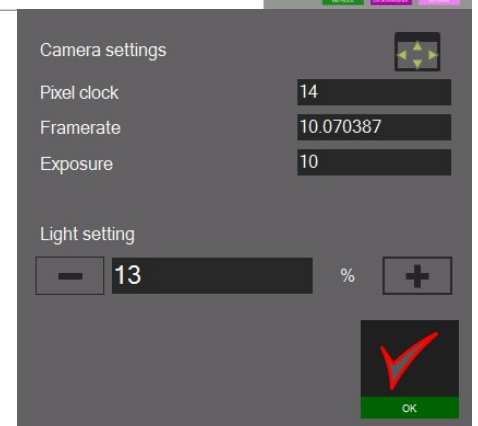
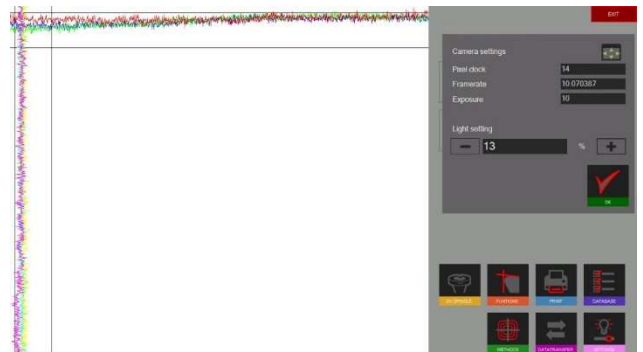

4.5.2 Align camera

Position the master mandrel, or a tool, of which the contour is parallel to the camera vertical axis.



Click this icon to adjust the camera.
Move the master vertical contour to the ROI/Region of Interest (blue rectangle).

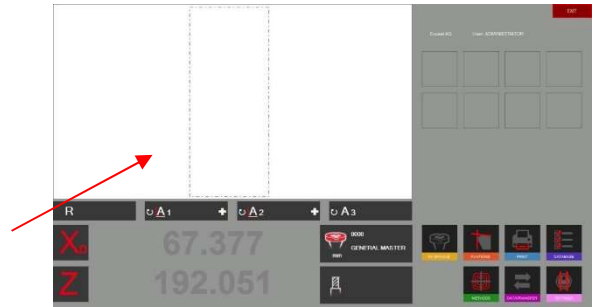

The "A1" angle indicator shows the difference between the mandrel vertical contour and the camera vertical axis.

The value must be less than $\pm 0.02^\circ$.

⇒ Permitted values: $179.98^\circ - 0.02^\circ$

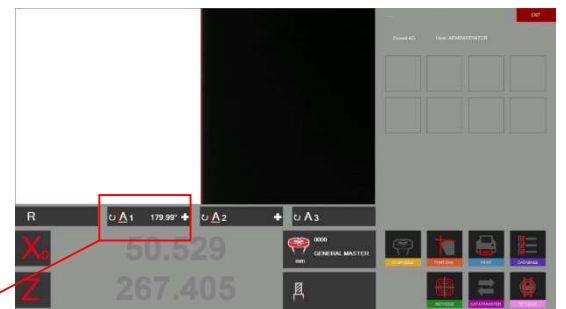

If the value is greater than $90 \pm 0.02^\circ$, loosen the fixing screw on the aluminium camera support.
Turn the camera slightly until the maximum permitted value is reached.

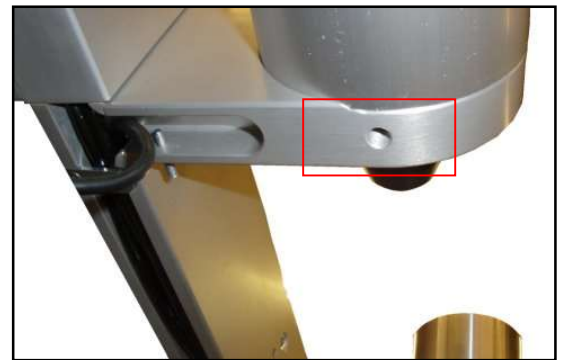

4.5.3 Parallelism correction

This function is used to adjust parallelism errors between the column and the outer ring axis.



Start the operation by clicking this icon.
Fit the master mandrel.

The software prompts to measure the first point at the bottom of the master mandrel.
Move the camera down and confirm the measurement.

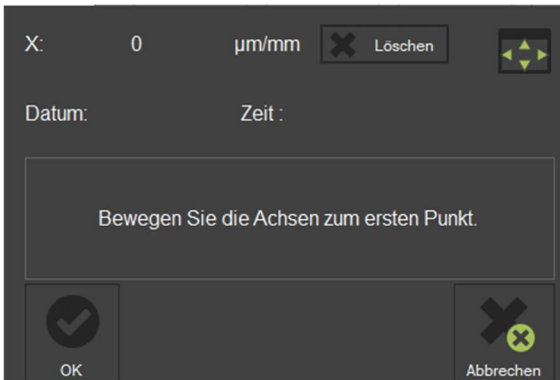
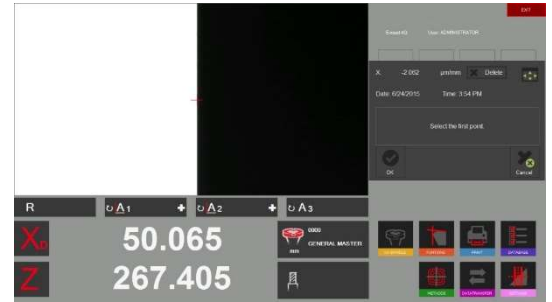

Move the camera up and measure a second point on the upper end of the master mandrel.

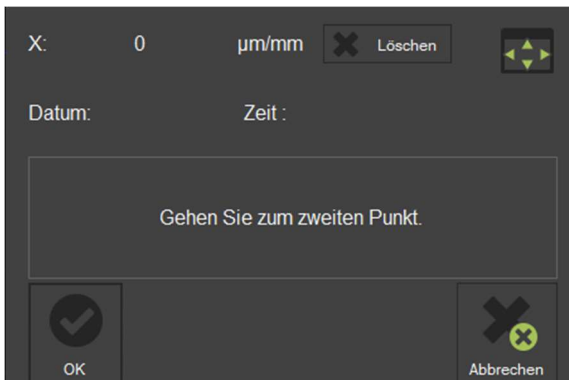

Confirm with



The result is displayed in the window, as shown on the right.

0.034 micron/mm indicates a correction of 0.01 mm over a height of 300 mm.

The software will now permanently correct this fault.

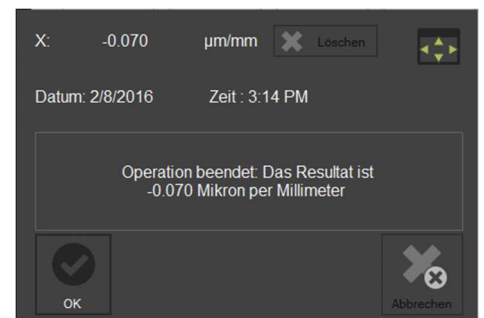

As soon as the parallelism correction procedure is complete, the system will request device calibration.

This must be carried out because of the new recorded parallelism error factor.

See section "4.5.4 Setting the absolute point zero" for further advice.

4.5.4 Absolute point zero / Calibration

Fit the master mandrel.



The left icon starts the procedure.



A window is displayed showing the master mandrel nominal values (engraved on the mandrel). If the values are different from those on the mandrel, they can be changed using this window. The unit can also be defined (metric/inch).

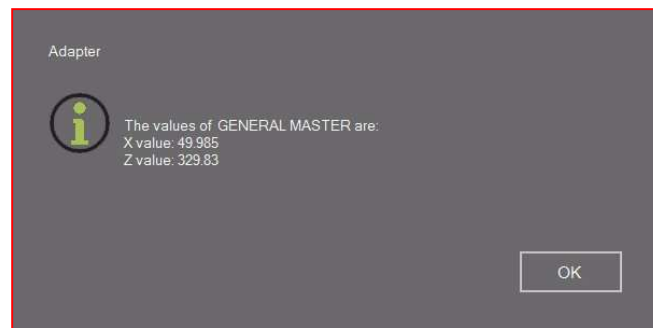

Check that the values in the reference control window are the nominal values. Master mandrel: Compare the values with those engraved on the master mandrel.

Confirm using "OK" to set the absolute point zero. The unit is now calibrated and ready to measure.

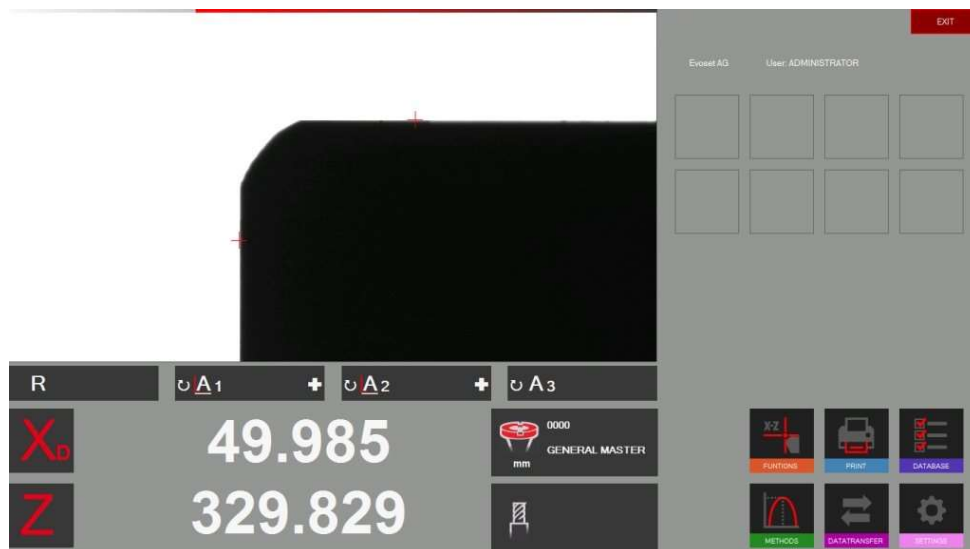

4.5.5 Camera pixel adjustment



The 0.0 icon starts the procedure

A window appears showing the number of pixels



Place the standard in the presetter spindle and align the red axes with the green cross that appears at different points on the screen at each step.

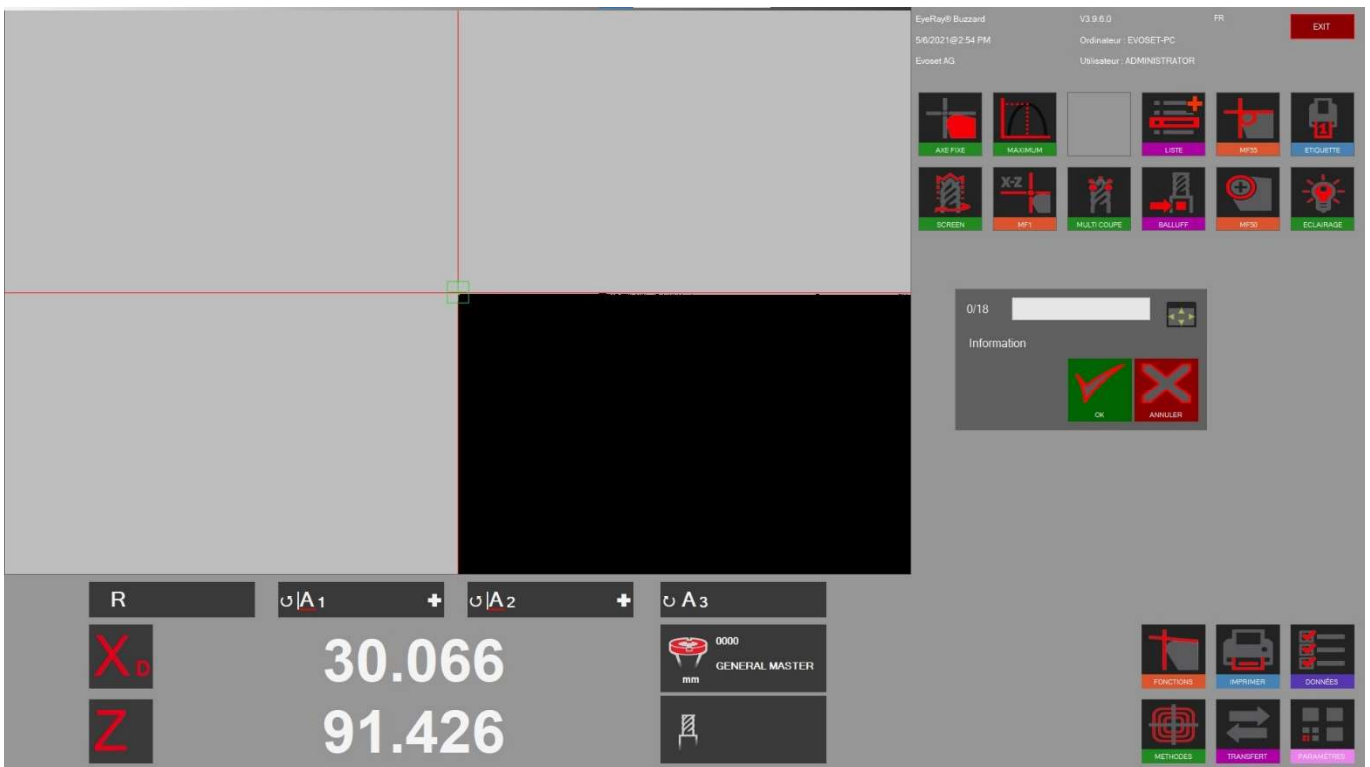
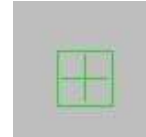

Then click OK
Point 1 of 18 is complete!

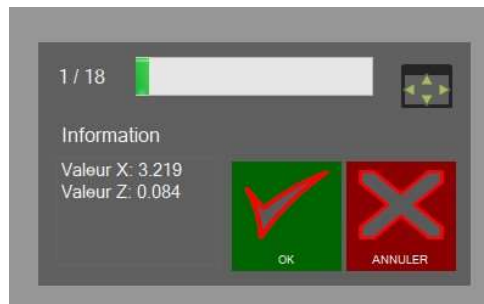

The operation must now be repeated 17 times.

4.5.6 Parameters

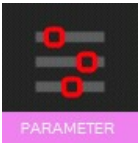

Display the parameter menu by clicking on the left icon.



An Administrator login is required to enter the parameters.

"General" tab:

- To change the company name, Language, Logotype, etc.

Options" tab:

- Modify the maximum method factor/angle factor etc.

"About EyeRay..." tab

- To open the user manual, online support connection, and contact information.

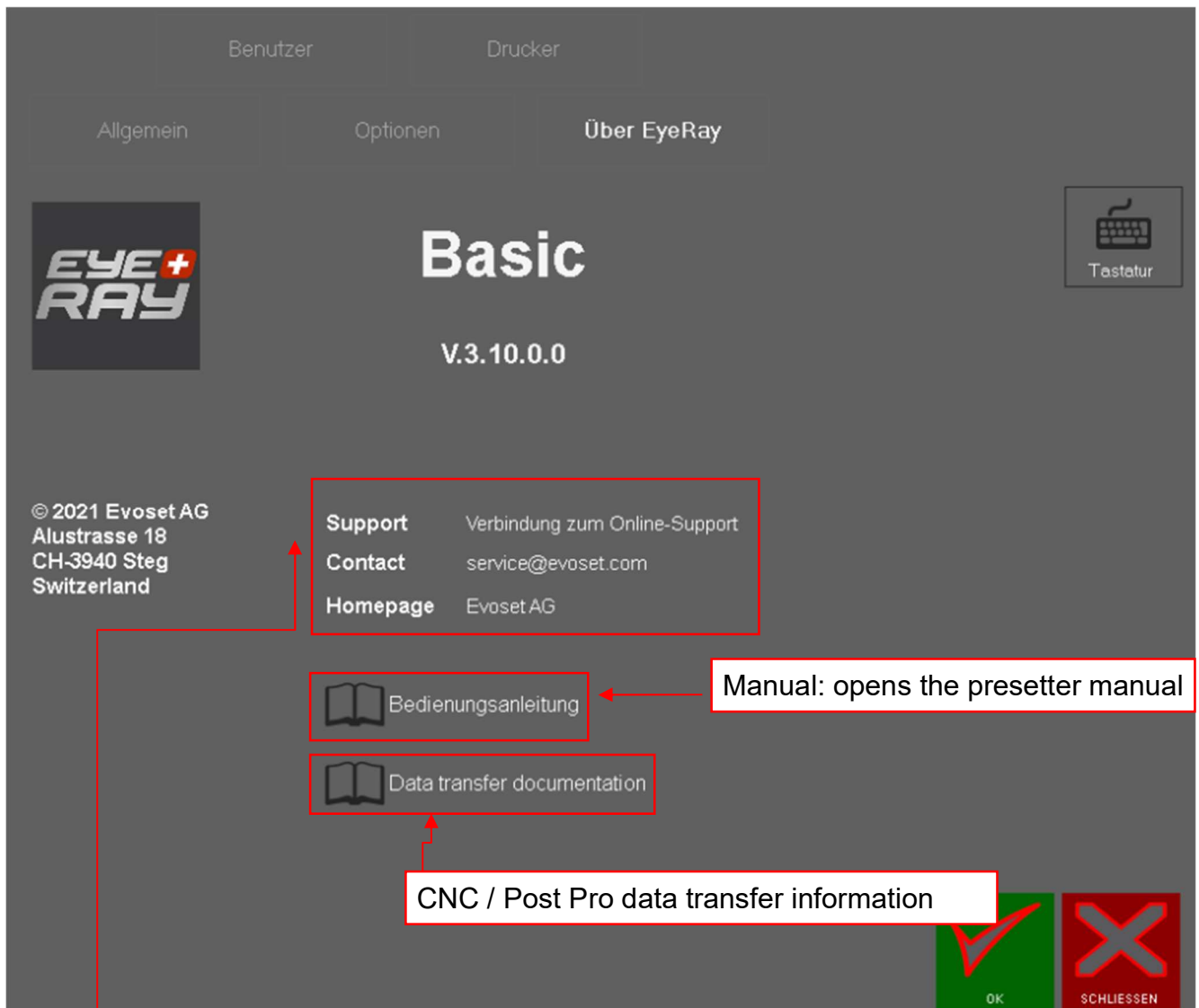

"Support": **Important!**

- Internet connection required!
- Automatically opens a website to enter a 6-digit code for online support.

"Users" tab

- User administration/user rights definition

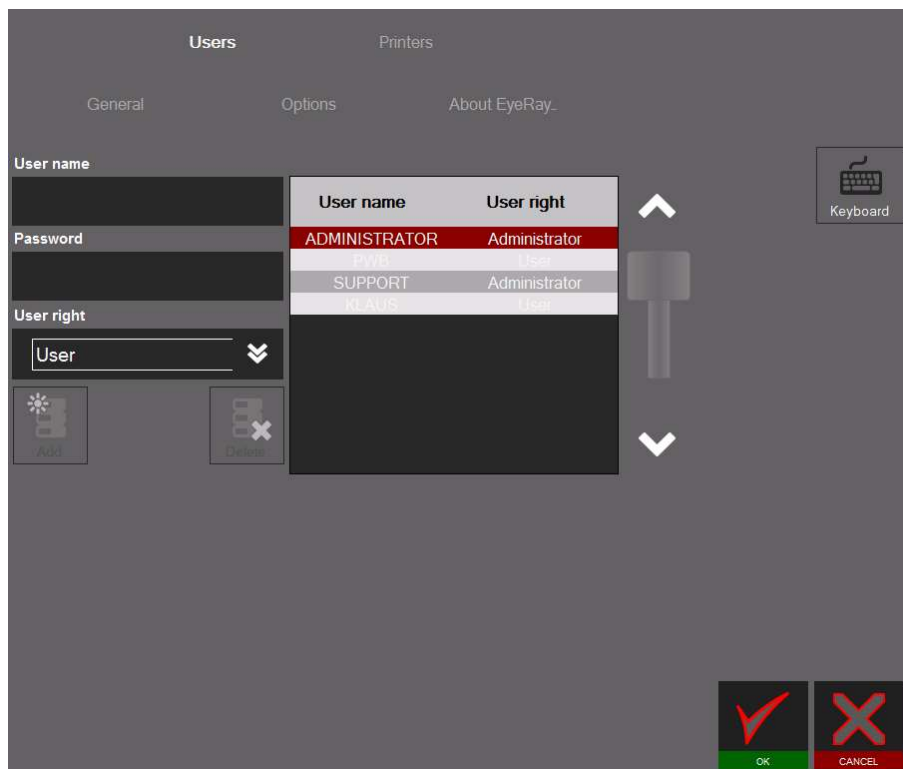

How to create a user

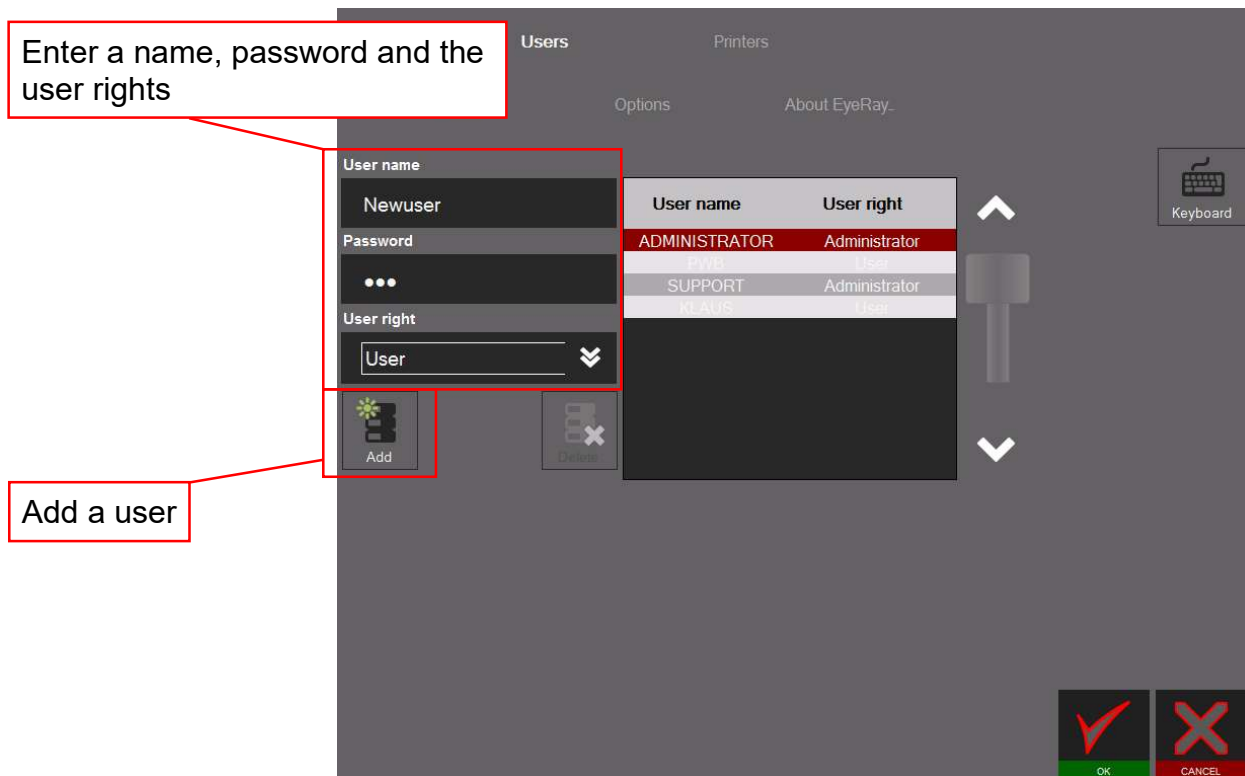

The "Support" user cannot be modified or deleted.

To delete a user:

Select a user from the list

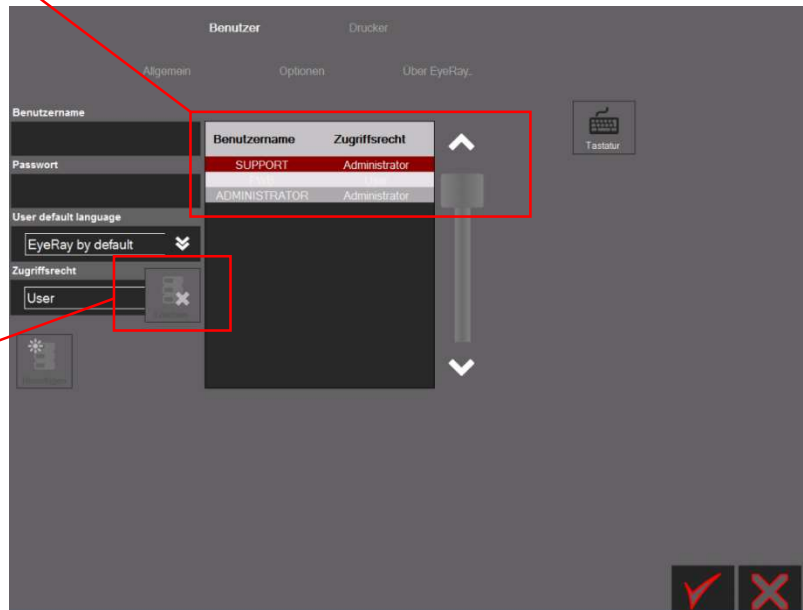

Delete

After confirming the displayed message, the user will be deleted.

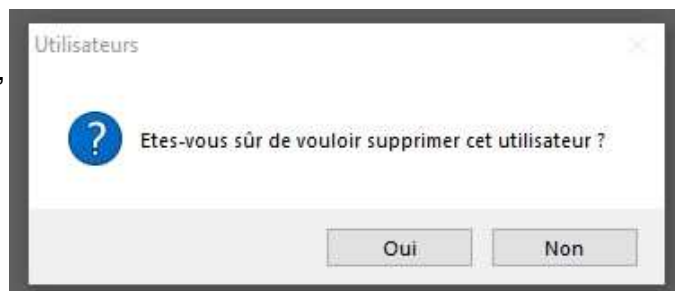

"Printers" tab

- Installed printer selection



4.6 Short cuts

Short cuts can be created to save time when activating frequently used functions and methods.

a maximum of 8 short cuts can be created.

If all the short cut fields are used, a new one can be created by overriding an existing field.

4.6.1 Create short cuts

Click and hold the left mouse button at the **bottom** of the icon to which you want to add a short cut.

Example: MF1 measurement function



Move the icon up to a short cut field using the left mouse button.

If the field is already used by a short cut, it will be overridden by the new one.

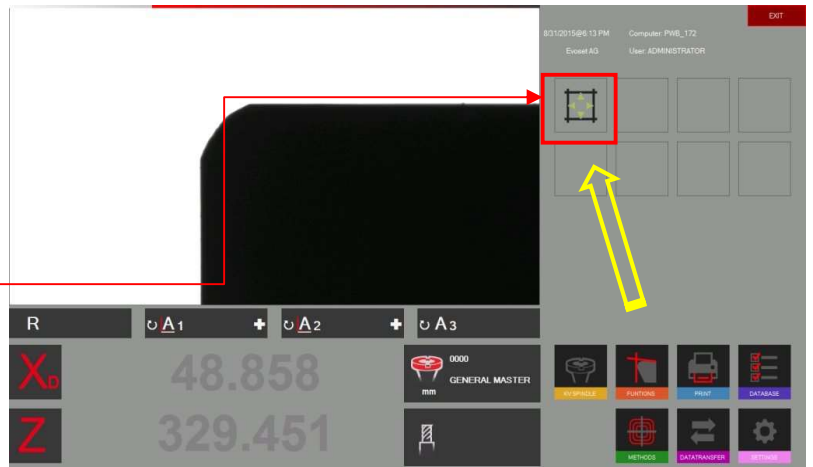
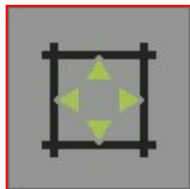

The function will now be in the short cut area.

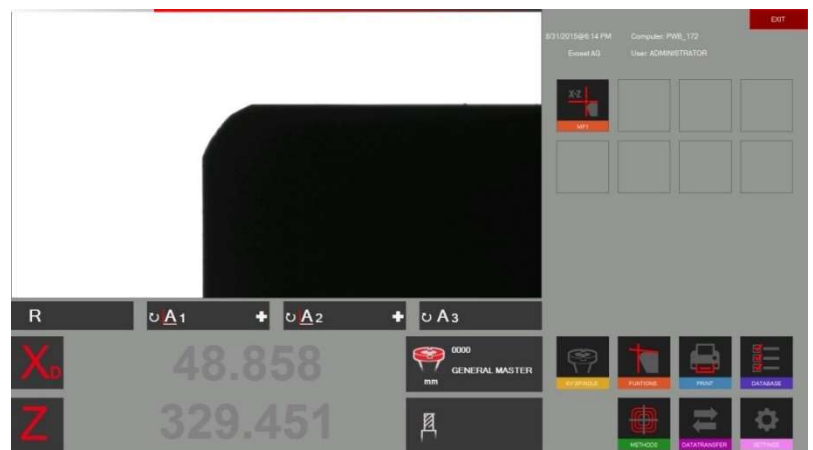

4.6.2 Deleting short cuts

Right-click the shortcut you want to delete and “Delete”

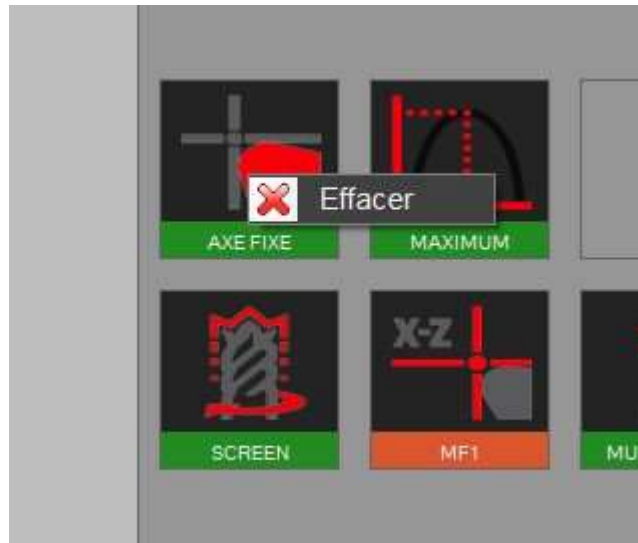

Various examples of function and method shortcuts are given below.

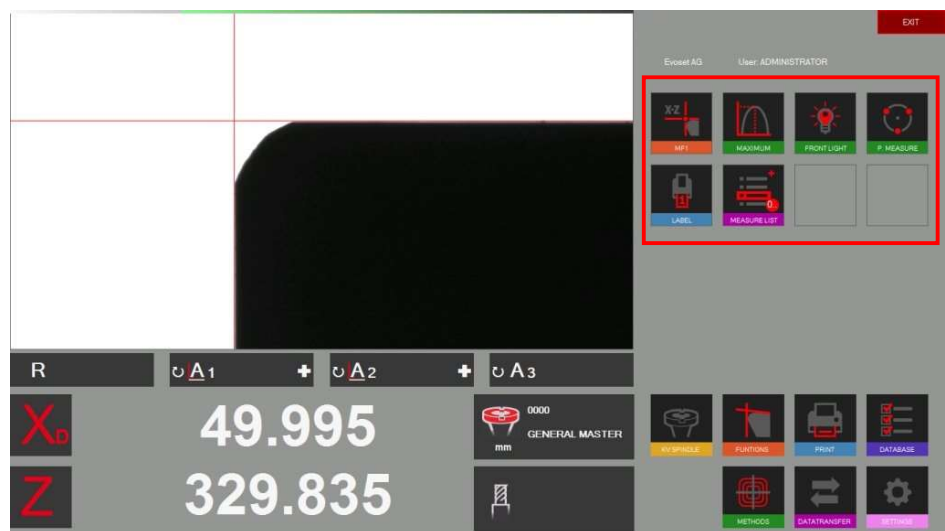

A maximum of 8 short cuts can be created.

4.7 Measurement

4.7.1 Focus indicator bar

Description:

The focus bar and maximum indicator help to turn the tool to its maximum deflection, and also to make sure the camera is in maximum focus.

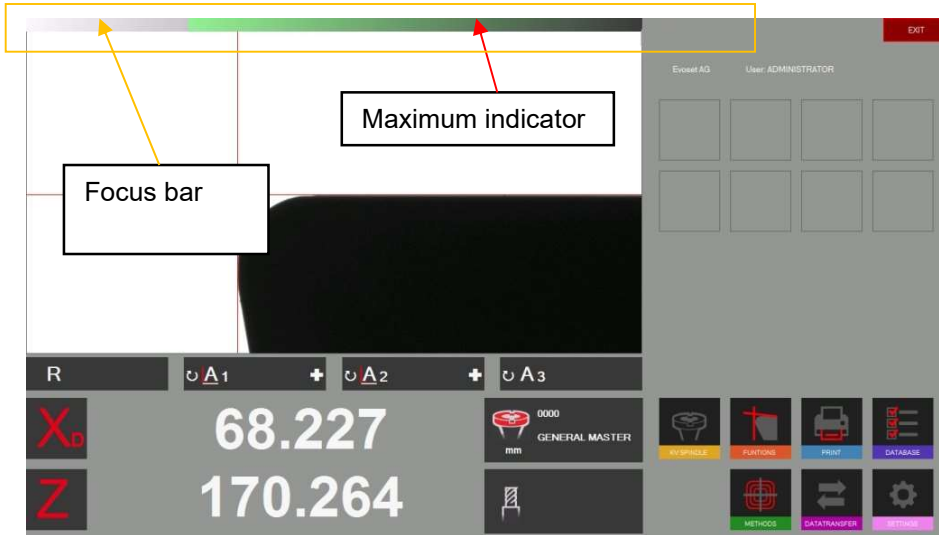

It is located in the top left corner of the camera area.

When the tool is slowly rotated in the camera area, two arrows (maximum indicator) on the focus bar move to the left until the maximum is reached, and then return as the tool continues to be rotated.

Slowly rotate a tool to see how the focus bar works.

How to use the Focus Bar

Place a tool and move it over the camera live image.

Rotate the tool => the arrows (maximum indicator) move to the left and are black



Rotate the tool again until the arrows point to the right and turn red. This means that the maximum focus has just been overshoot.



Rotate the tool slowly in the opposite direction until the arrows turn GREEN



If the focus indicator does not need this it is automatically minimised



4.7.2 Selecting a reference point

Place a tool.

Before measuring a tool, the "correct reference point" must be selected.

Click the reference point icon.



A list of all the defined reference points is displayed.

Adapter N°	Name	Mode	Select
0000	GENERAL MASTER	Reference Value	<input checked="" type="checkbox"/>
1	ISO50	Offset Value	<input checked="" type="checkbox"/>
10	HSK 63	Offset Value	<input checked="" type="checkbox"/>
11	sk40	Offset Value	<input checked="" type="checkbox"/>
22	Sk 30	Offset Value	<input checked="" type="checkbox"/>

Close

Icon description:



Use the arrows to scroll through the list



Press to select a reference point

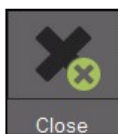

Press to close the list without selecting

The selected reference point will be illustrated in the reference point window

Example:



Reference point number and name



Two different types of reference point/adapter can be stored:
- Adapters with reference values
- Offset adapters

Adapters with reference values

This type of reference point is used to calibrate the unit.

Examples: Master mandrel/"Master tools" of known dimensions/calibration tools

An adapter, with stored reference values, is mainly used to calibrate the unit.

=> General Master/Master Mandrel.

Offset adapter/Adapter with offset value:

This type of reference point is used to measure tools with tool supports other than the base spindle.

Examples: PWB adapters such as ISO/HSK/Capto etc.

It is the offset value mainly used with the Z axis. The diameter axis is usually equal to the centre of the outer ring => no offset needed (exception: lathe tools, for example)

Indication of an adapter with reference values/absolute reference point:



The adapter symbol highlighted in red indicates that this adapter is an "absolute reference point"

In red => Adapter with reference values = MASTER



Note: The unit must be calibrated using the assigned calibration tool when selecting an adapter with reference values!

4.7.3 Select a measurement function (MF)



This icon activates the elementary measurement functions.

Most tools can be measured using the 9 elementary measurement functions.

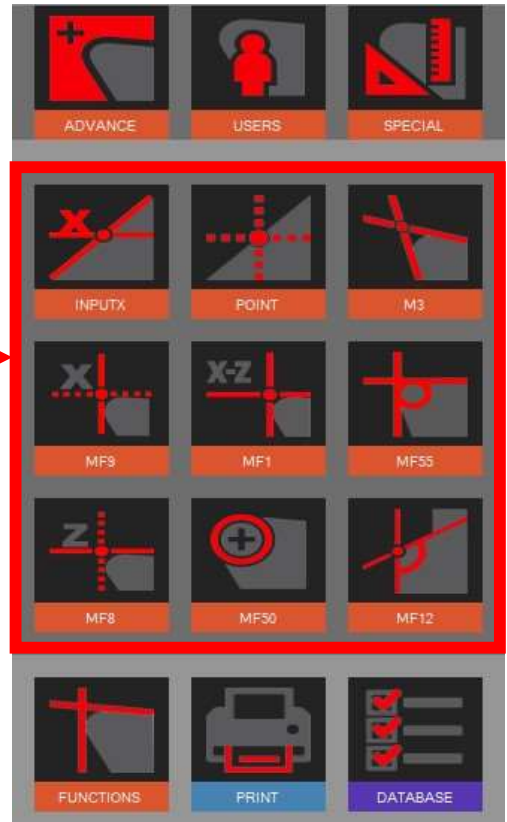

Activation of additional measurement functions



Shows the user the defined/custom measurement functions.

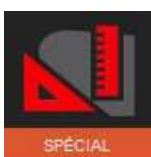
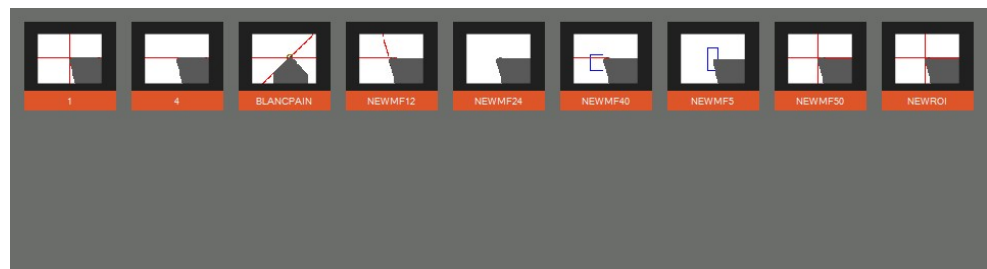

Special measurement functions (on request)

Evoset/PWB item number: P270590.

See section 5.8 "Custom measurement function".

4.7.4 Measurement function descriptions

Usually:

The measurement function defines how the imaging system analyses the insert or cutting edge.

4.7.4.1 Elementary measurement functions



MF1

This function measures the highest point on the tool contour in the horizontal direction (X) and the highest point in the vertical direction (Z): this is known as point measurement.



MF8

This function only measures the highest point on the tool contour in the vertical direction (Z), which means only the tool length.



MF9

This function only measures the highest point on the tool contour in the horizontal direction (X), which means only the tool diameter, radius.



M4

This function places the two measuring lines L1 and L2 on the tool contour and measures the angles of the two lines and also the angle between them: this is known as line measurement. It is also used to measure the radius of the tool's cutting edge.



X input and inverted X input (additional function)

This function measures the height of a contour using the default diameter value. It also indicates the cutting edge angle.



MF0



Using this function, it is possible to measure (or check) the master mandrel by measuring a single point on each axis, one in the horizontal direction (X) and the other in the vertical direction (Z).

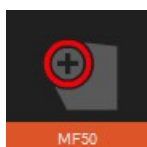

MF50

This function measures the radius of the tool's cutting edge and displays it together with the centre point of the radius.



MF22

This function places the two measuring lines L1 and L2 on the contour of the tool and measures the angles of the two lines and also the angle between them. At the same time, it measures the radius of the tool's cutting edge, the highest point in the horizontal direction (X) and the highest point in the vertical direction (Z).

(MF22 = combination of M4 and MF1)



MF12

This function places the two measuring lines L1 and L2 on the contour of the tool and measures the angles of the two lines and also the angle between them. It also measures the radius of the tool's cutting edge.

Difference between MF12 and M4:

The **MF12** function is also used to create user/custom functions, changing the size and position of the measurement areas for both lines and the radius.

=> **See section "4.7.4.3 Custom measurement functions"**

4.7.4.2 Additional functions/measurement ranges



Z Input

Measurement of a contour diameter at a specified height.



M1

This function places the two measurement lines L1 and L2 on the tool contour and measures the angle of those lines.



M3

This function places the two measurement lines L1 and L2 on the tool contour and measures the angles of the two lines and also the angle between them: this is called the measurement line. It also indicates the theoretical "X" and "Z" point of intersection.



MF24

This function measures the radius and centre point of a shape tool with an inverted radius.

(Milling cutter radius)



MF25

This function places a measurement line along the tool contour (Z value/measurement line) and captures the highest point on the X axis (measurement point).

The result shown is the point where the two lines intersect on "X" and "Z".



MF26

This function places a measurement line along the tool contour (X value/measurement line) and captures the highest point on the Z axis (measurement point).

The result shown is the point where the two lines intersect on "X" and "Z".



MF40

Measurement line: this function places the two measurement lines L1 and L2 on the tool contour.

It indicates the angles of the two lines and also the angle between them. The point of intersection of the lines will also be indicated ("X" and "Z"). (counter drilling/drill bit to be centred)



Angle

Measurement line: places measurement line L1 along the contour of the cutting edge and indicates its angle.



MF55

This function measures the highest horizontal (X) and vertical (Z) point and the direction (PX/PZ).

The cutting edge radius will also be indicated.



MF14

With the centre point method, the vertical line in the middle is just one pixel along the camera active view. The measurement point follows the cutting edge.

Application: measurement of the axial runout of a disc or circular saw blade.



RUNOUT

Runout check

4.7.4.3 Defined/custom measurement functions.



The EyeRay® **USERS** option makes it possible to create custom measurement functions.

Because of the innovating and flexible nature of EyeRay®, users can modify/replace a measurement function and save it as their own 'custom' function.

The MF12 function is mainly used to create custom functions:



MF12

Select MF12 and click in the camera image area using the mouse.

Two blue rectangles (Regions of Interest/ROI) will be displayed in the active image and a control window will open.

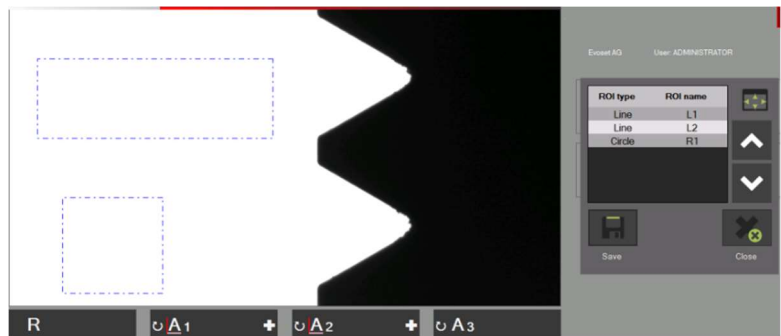

Functions in the control window:

Select a region of interest (ROI)

Save the custom function

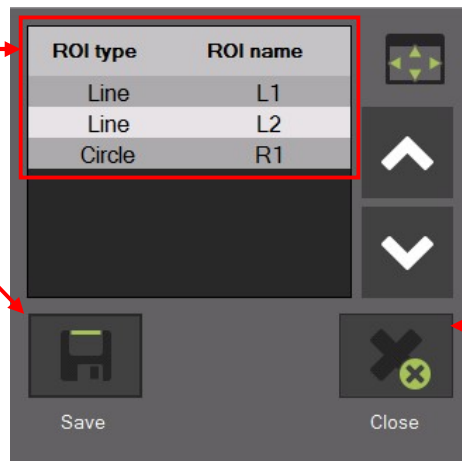

Close the control window

Define the ROI

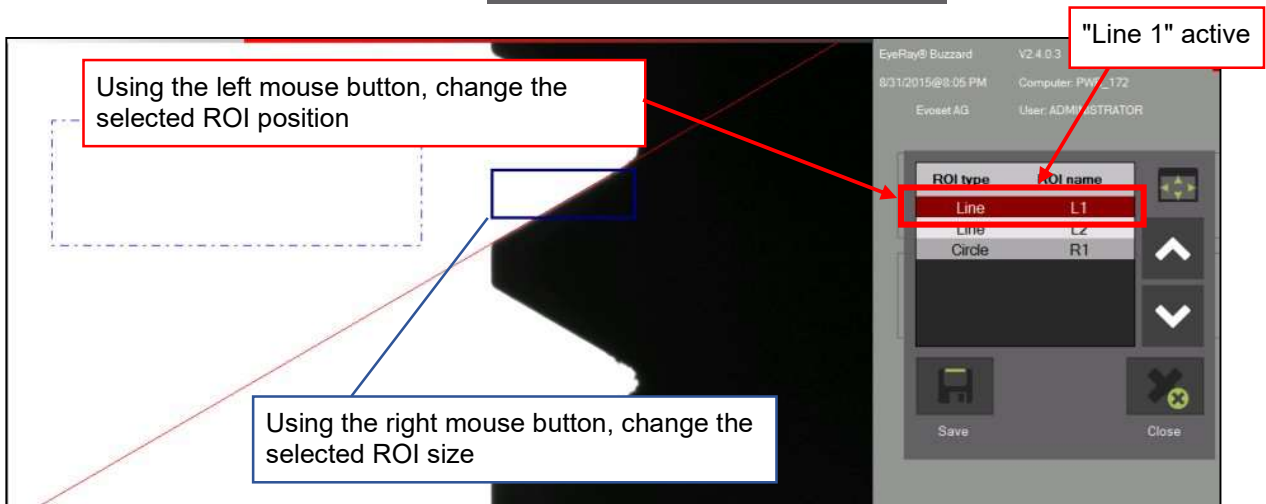

Position the two lines and the radius (if required) at this point.

Save the custom function:



Click this icon to save the function.

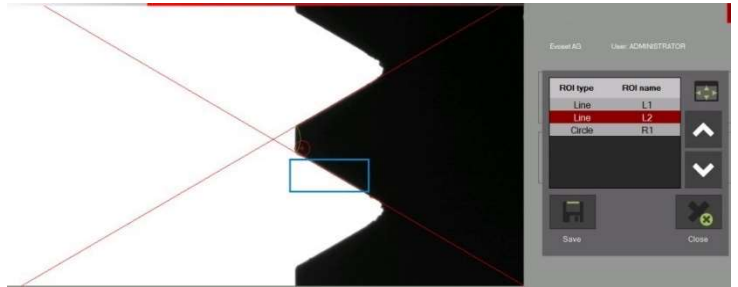

- Enter a name and confirm with



- Close the control window with

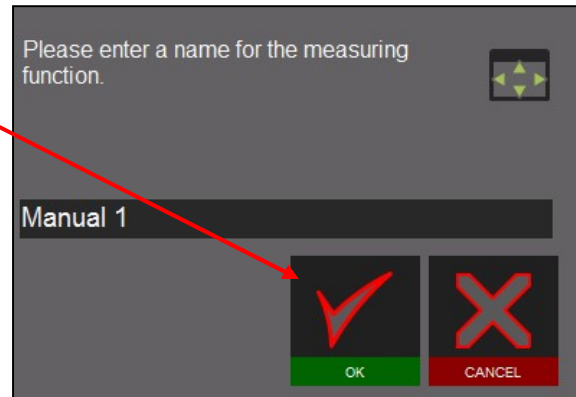
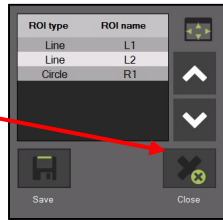
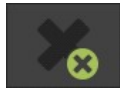

Select a custom function:



Click this icon to display all the custom functions

Click the icon for the required function

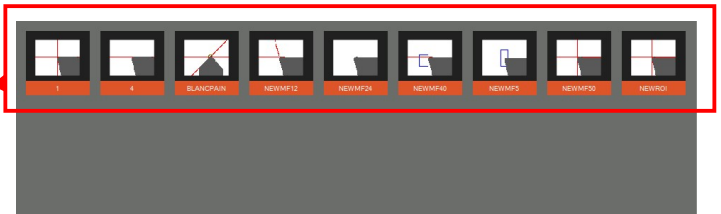

Delete a function:

Right-click the icon to display the "Delete" message and select

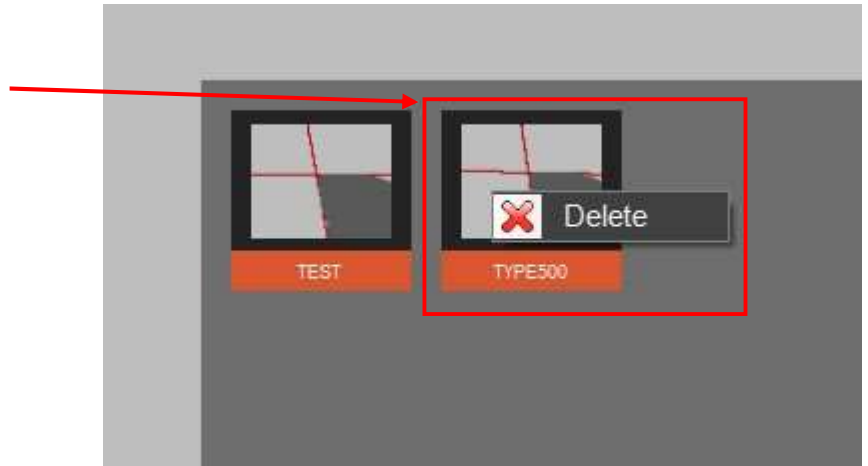

4.7.5 Select a measurement method

The user selects the method they want to use to measure the tool.

The measurement methods are listed on two pages. Scroll through the pages using the arrow icon.



Measurement methods icon.

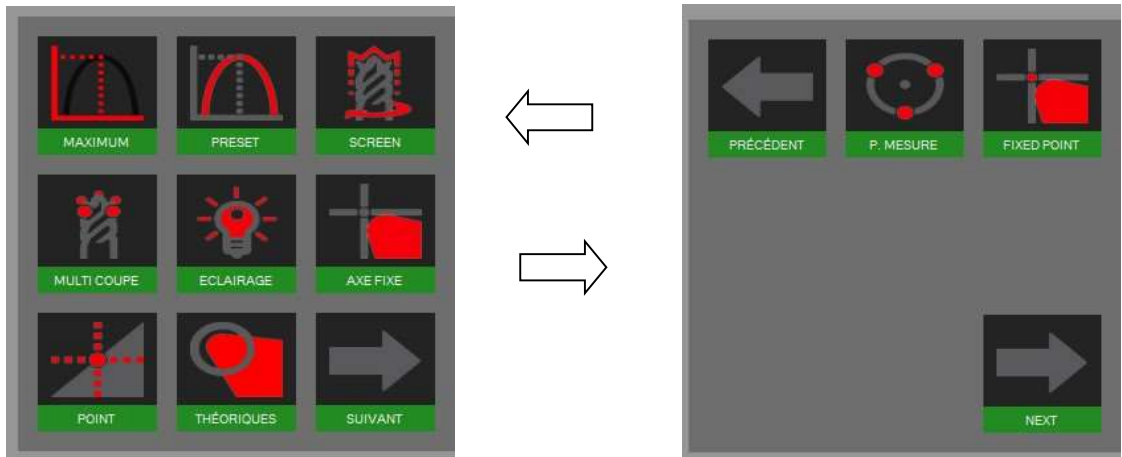

Symbols/methods:



Maximum method



Fixed axis method



Pre-set method



Centre point method

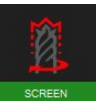

Screen method

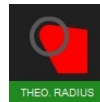

Theoretical angle/radius



Multi-cutter method



Point measurement



Front light method



Fixed point

4.7.6 Measurement method descriptions

4.7.6.1 Maximum method



Use this function to measure the **maximum values of X and Z** without using the focus bar => rotate the tool and the maximum values will be displayed.

Rotate the tool slowly in the camera's field of vision. The software automatically selects the highest point and places the measurement line at that position. The values shown are the maximum values for the tool.

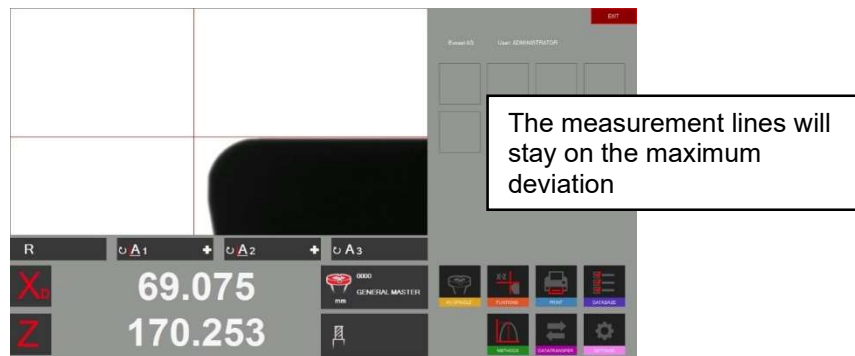
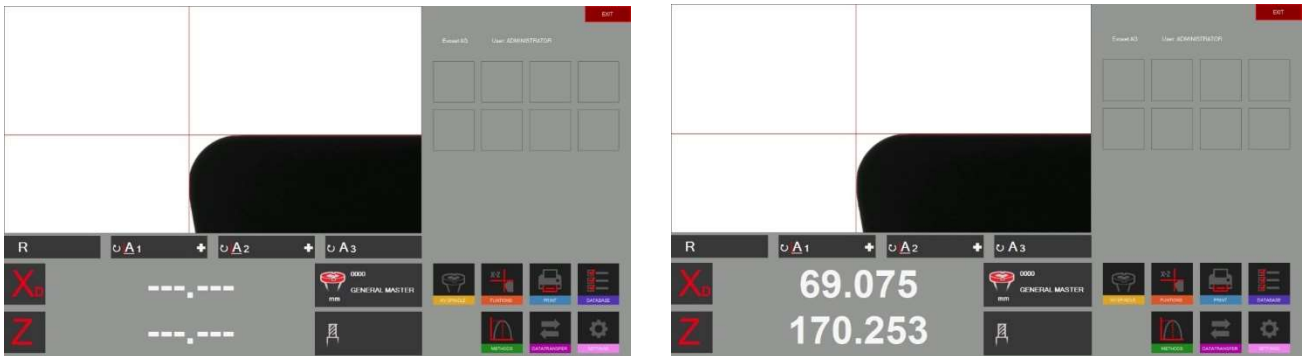

If the tool is removed from the camera's field of vision, the system will carry out a reinitialisation according to the timer settings in the parameters (Section 4.5.5/Parameter/Index options).

The "X" and "Z" counters show dotted lines.
The system is ready to measure the next tool

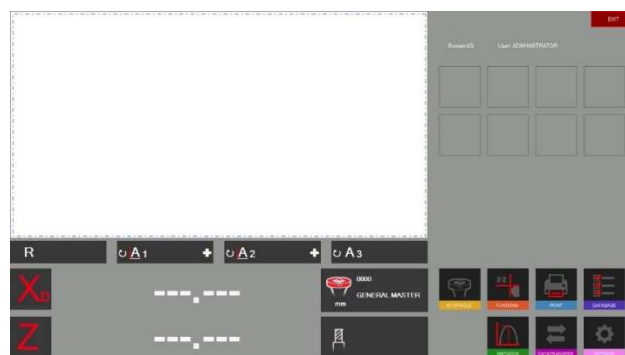

4.7.6.2 Pre-set mode



Activate the "Pre-set" (adjustment) method using the icon on the left.

Purpose of the pre-set function: This function is used to set a boring tool to a specific \emptyset and length.

Difference with the "Maximum method": The measurement lines will always follow the cutting edge.

Position the tool and adjust to maximum focus using the focus indicator at the top left of the live image.

When Pre-set is selected, it will be the maximum for the tool. The lines will now follow the cutting edge to set a specific tool dimension.

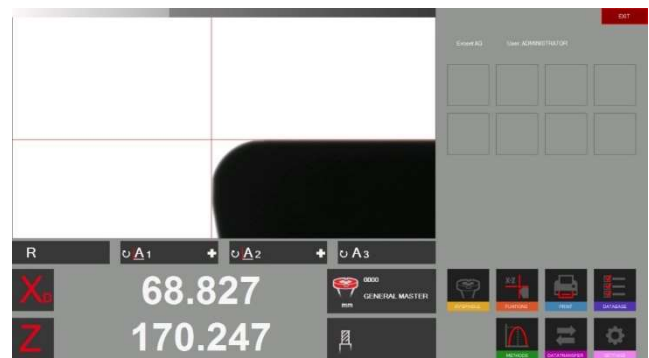
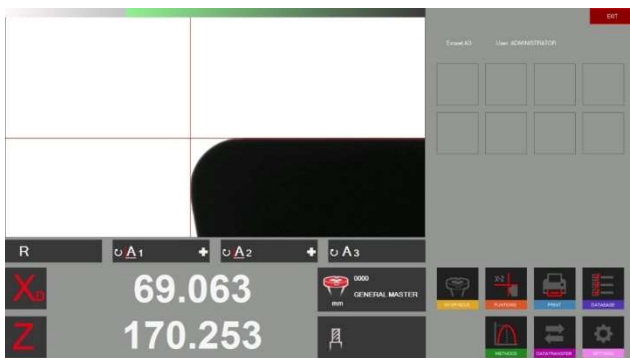

The measurement lines will always follow the cutting edge.

4.7.6.3 Screen method

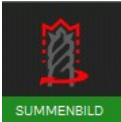

Purpose of the Screen function:

This function is very useful when the tools to be measured are helical, for example a drill bit, or a ball-end mill cutter, or tools that have several cutting edges.

Tools with such shapes cannot always be measured by looking for the highest point. An image of the complete tool is required. The "screen method" fully meets this requirement.

Activate the function using the icon and rotate the tool slowly one turn in front of the camera field of vision.

The result displayed in the live image area is the contour that the tool will leave on the part being machined.

Measurement is now possible by selecting the measurement function.



Example using a ball-end mill cutter:

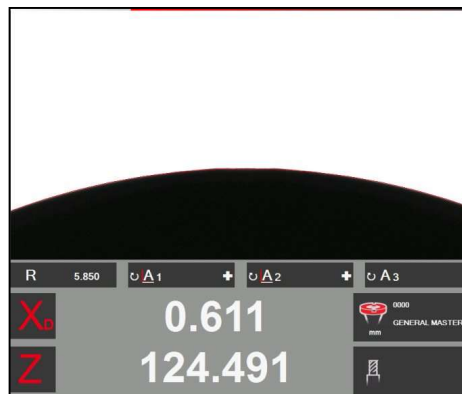
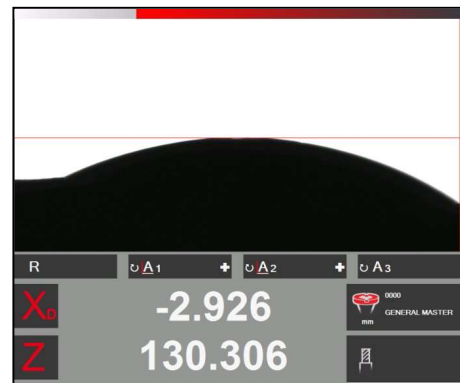
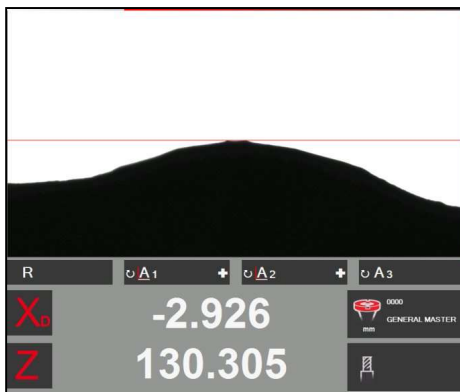

Example: measurement using MF50

4.7.6.4 Multi-cutter method

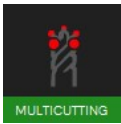

Measurement of a tool with several cutting edges and edge comparisons can be carried out using the Multi Cutter method.



Enter the number of cutting edges on the tool

Activate the multi-cutter method

Select the values to be displayed

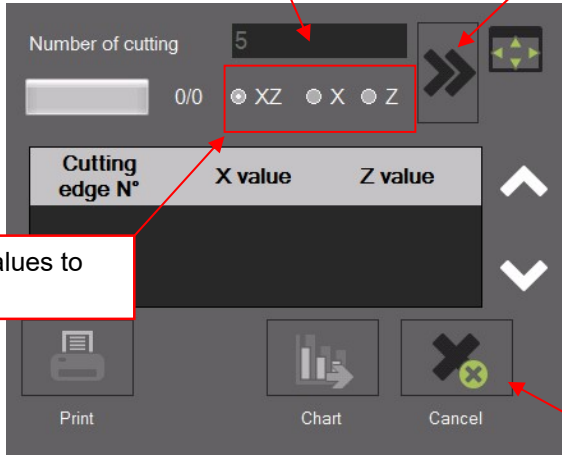

Deactivate the multi-cutter method

Use the icon  to activate the procedure:

Slowly rotate the tool until each cutting edge has been measured. The progress of the process is shown in the status bar. Note: the first cutting edge initialises the mode, after the procedure has started.



When all the cutting edges have been measured, the software displays a graph showing the results.

The results can also be displayed in table form.

The highest value is displayed in "green" and the lowest in "red".



4.7.6.5 Tool inspection method/front light (reflected illumination)

This method is used to inspect cutting edges, for example (surface checks, damage checks).



Use this icon to activate the Front Light/Tool method.

An inset window opens which is used to adjust the brightness of the front lighting and the cross-hairs.

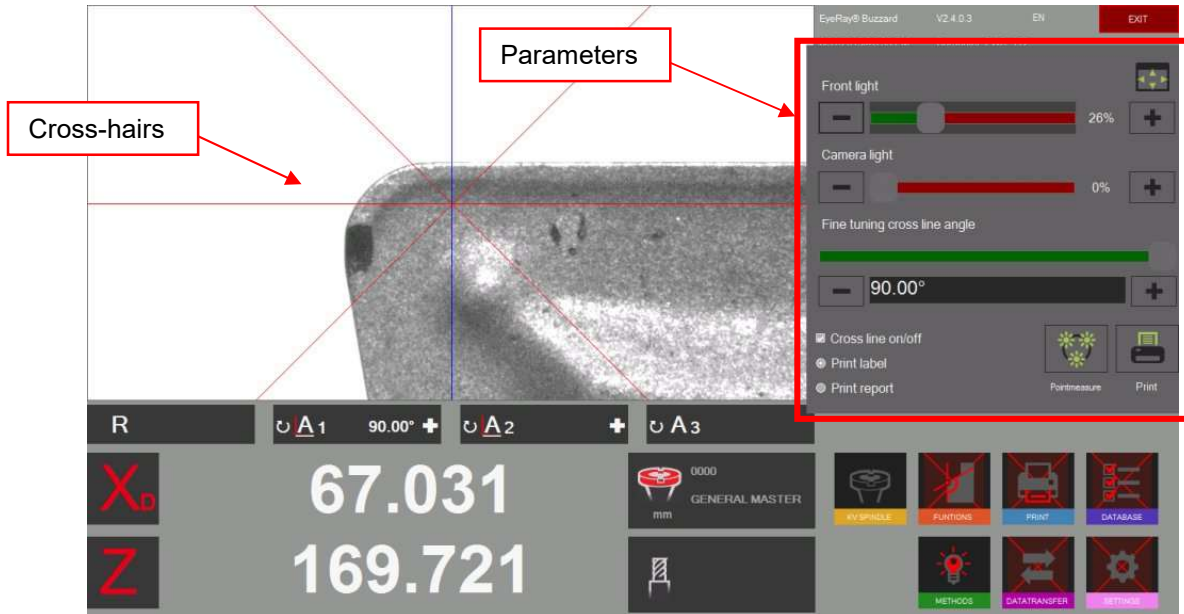

Left-click the cross-hairs to change their position. Breaks or defects in the cutting edge can then be measured.

Distances, radii and angles can also be measured using the "Point measurement method". See section "4.7.6.9 Point measurement".

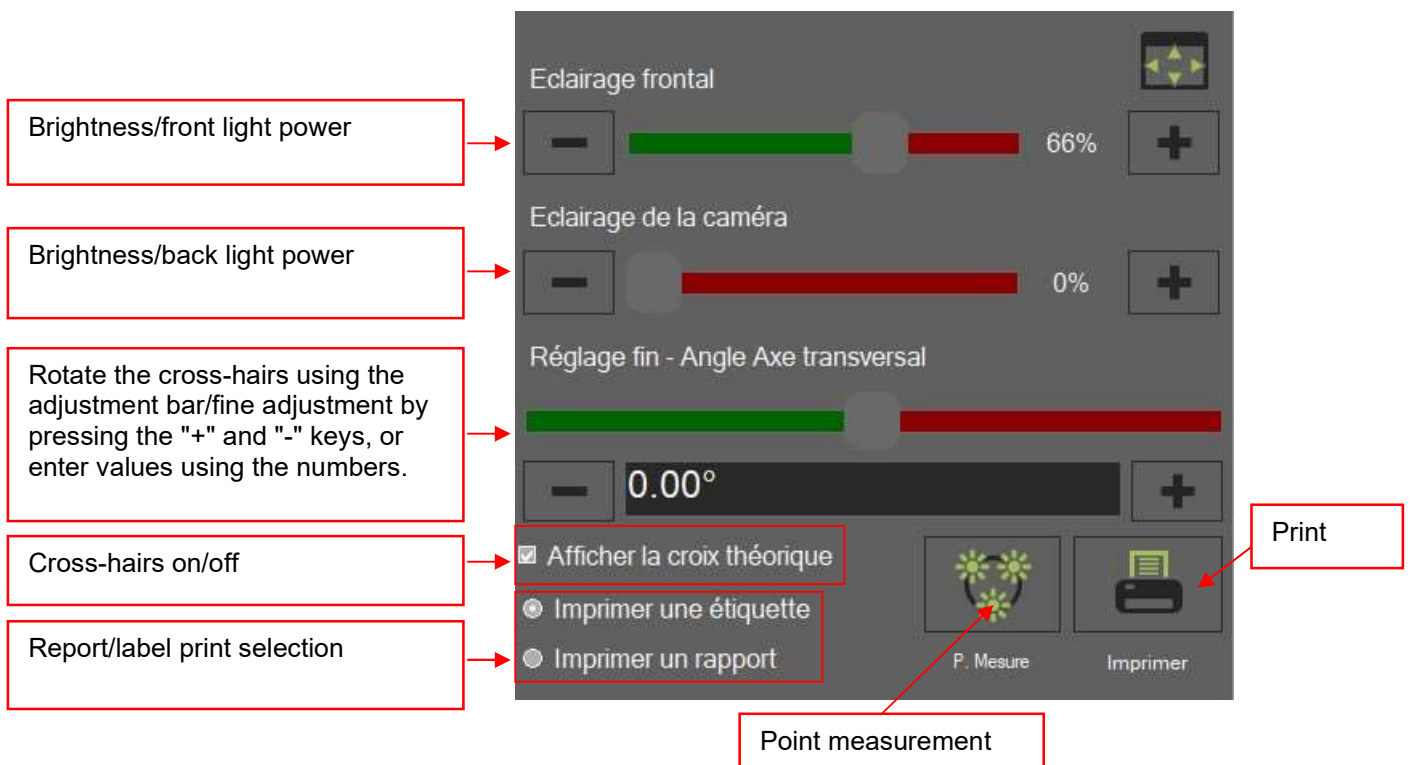

Example: Measuring damage in the Z direction using the cross-hairs:

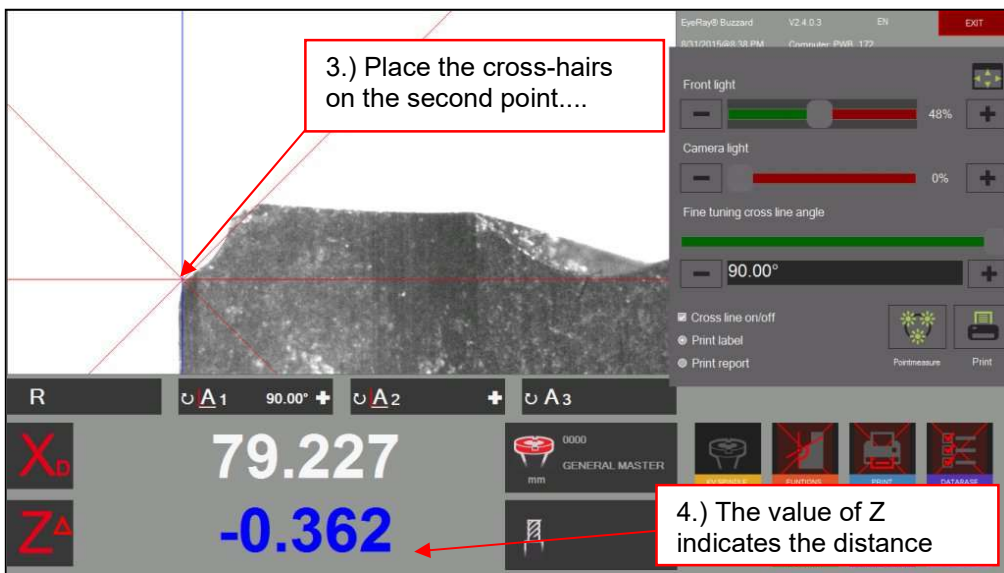
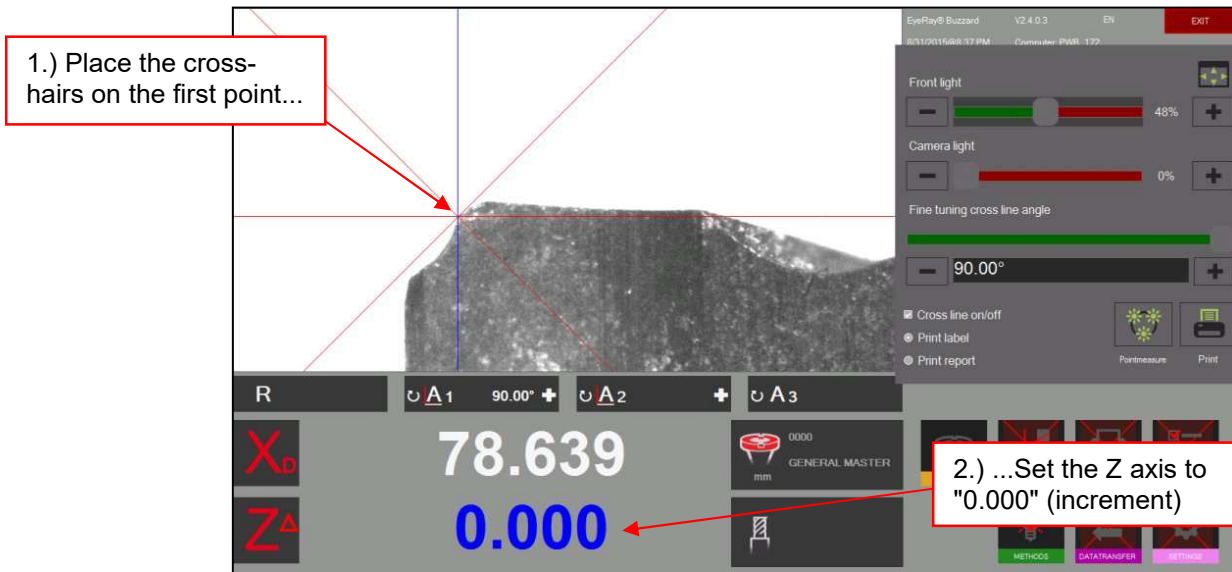

Measuring an angle using the cross-hairs:

Use the adjustment bar on the control box or use the "+" and "-" keys to set the cross-hair angle and measure an angle on the cutting edge.

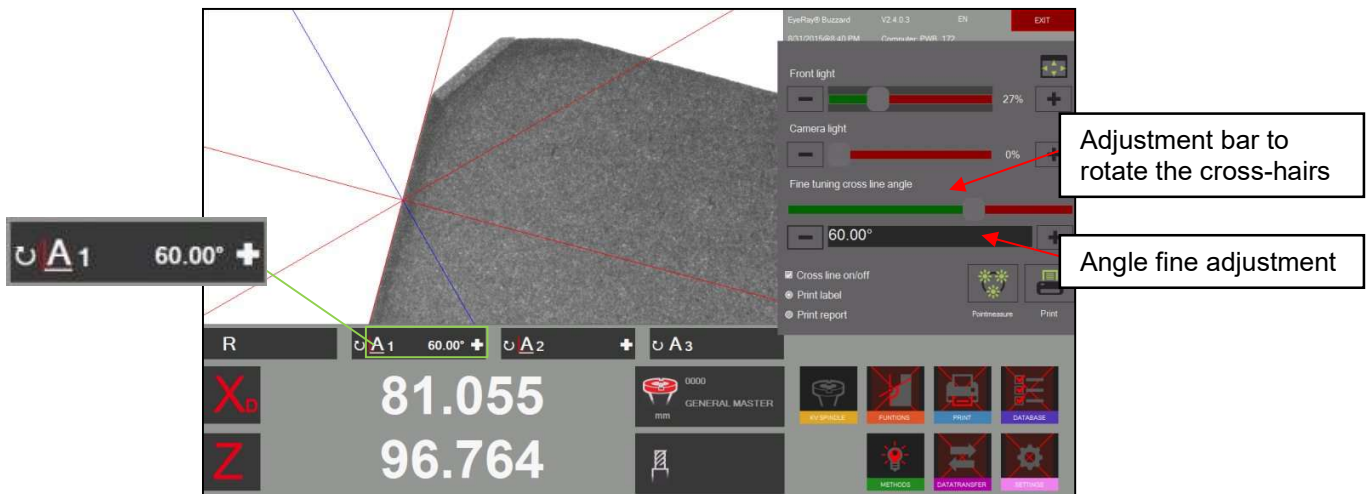

4.7.6.6 Fixed axes

This method is used to measure length and diameter of a fixed axis ("projector mode")



Click this icon to activate the "Fixed Axes" method.

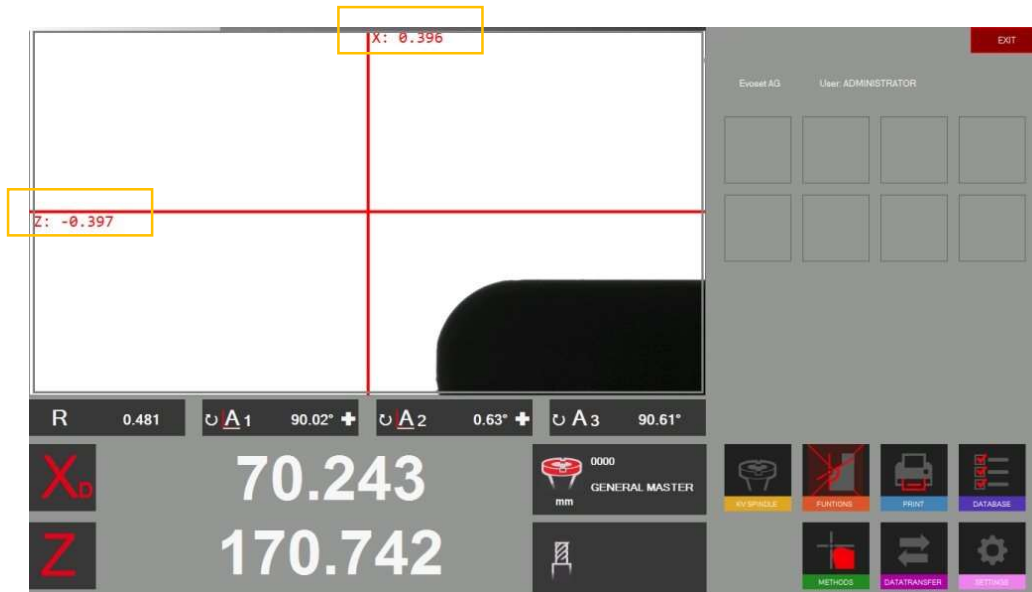

In the live camera image, a horizontal line and a vertical line (cross-hairs) are displayed.

Position the tool and adjust to maximum focus using the focus indicator at the top left of the live image.

Move the cutting edge using the measurement line fine adjustment.

If the tool moves closer to the line, its colour will change to **Brown** (thick line).

If the tool is only a few microns from the line, the colour will change to **Orange** (thin line)

When the line turns **Green**, the tool is touching the cross-hairs (the indicators show 0.000 mm).

If the measurement point is overshoot, the line will switch back to orange.

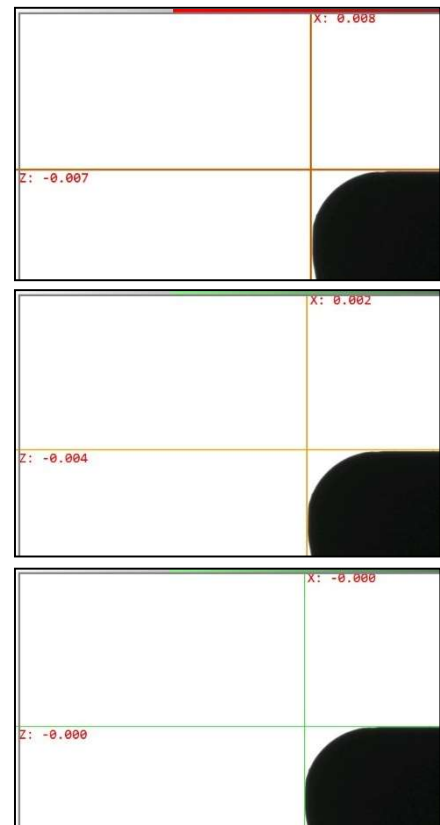

4.7.6.7 Centre point method

For the centre point method, the vertical centre line is at one pixel from the horizontal centre line in the active camera's field of vision.

Applications: checking the runout or \varnothing of a cylindrical part, checking the parallelism of the master mandrel using the tool presetter column.



Click this icon to activate the centre point method.

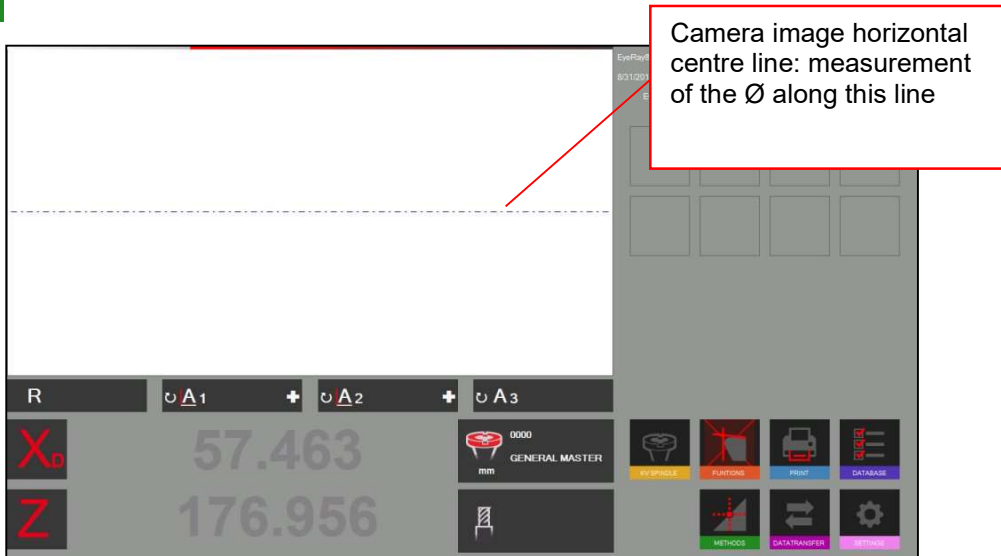

Place a cylindrical tool (master mandrel):

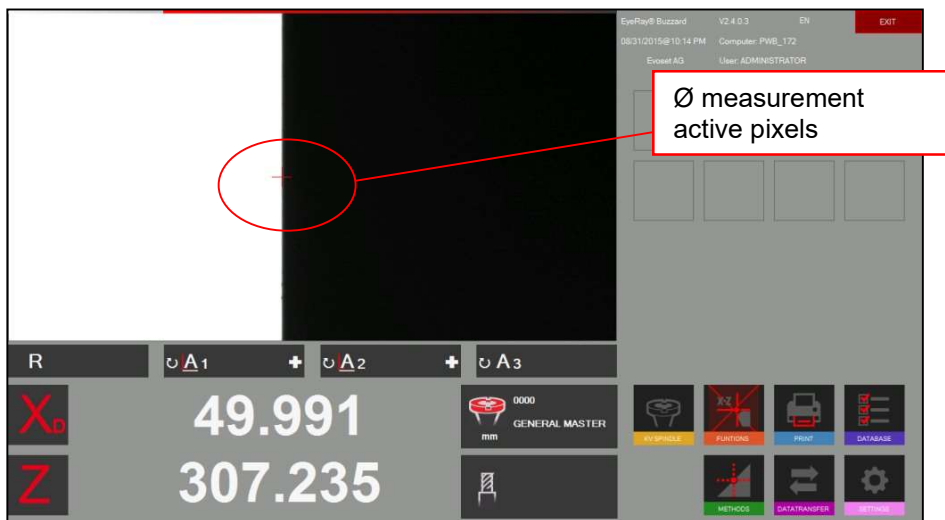

The software now shows the diameter and absolute height on the Z axis (fixed axis).

When the tool is moved to the left or right, the point will follow along the horizontal centre line.

Examples:

Measuring runout using the centre point method

Place a cylindrical shaft, or the master mandrel, in the ring and measure the diameter using the centre point method.

Set the X axis to zero and switch to Radius mode.

Rotate the tool => The X axis indicates the deviation.

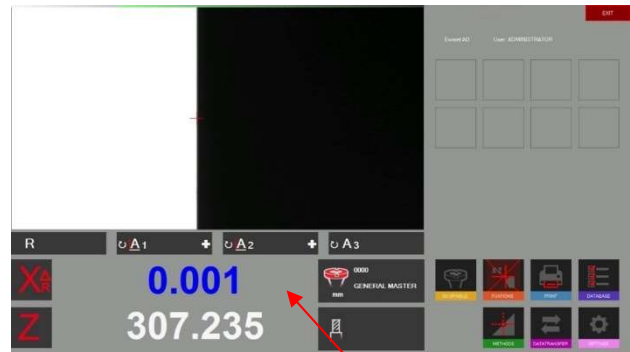
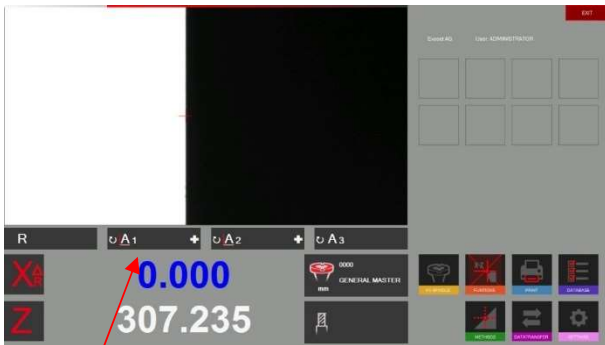

Set the X axis to zero and switch to Radius mode.

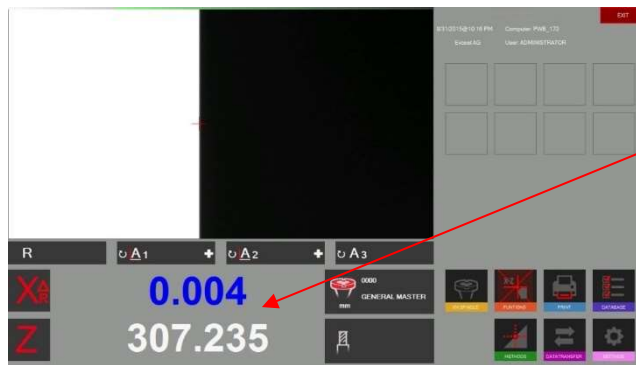

Rotate the tool: The X axis indicates the deviation

Checking that the mandrel is parallel to the column

Measure the diameter using the centre point method at the top of the mandrel. Set the X axis to "0.000" and switch to Radius mode.

Move the camera downwards along the mandrel.

The X-axis counter now indicates the difference.

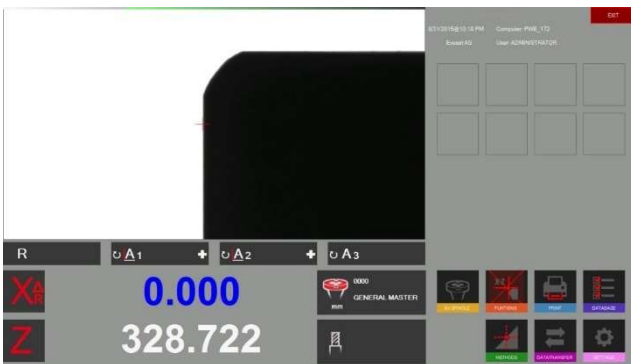

Measure the \varnothing at the top of the mandrel and set X to "0.000" and "radius"

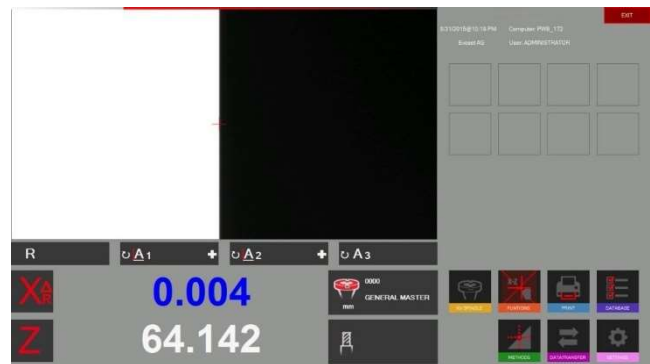

Move the camera down and measure the \varnothing at the bottom

4.7.6.8 Theoretical angle/radius



Use this icon to activate the theoretical "angle/radius" method.

This method is used to plot an angle or radius using default values.

A settings window opens:

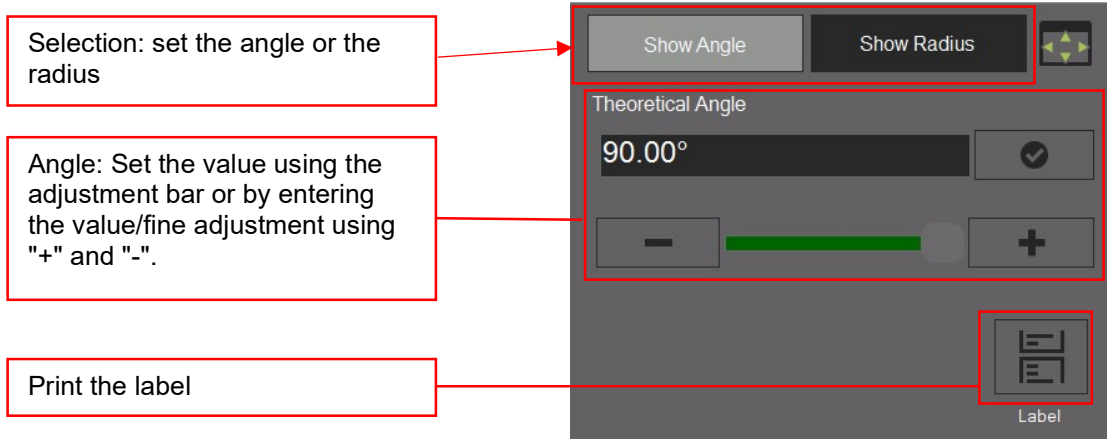

Use of the "theoretical angle" method:

Move the cross-hairs to the cutting edge using the mouse...

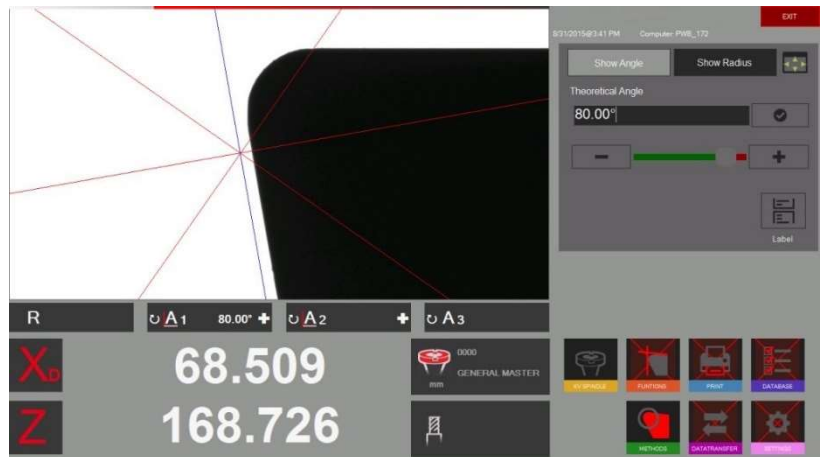

...and set the angle along the cutting edge using the adjustment bar and fine adjustment.

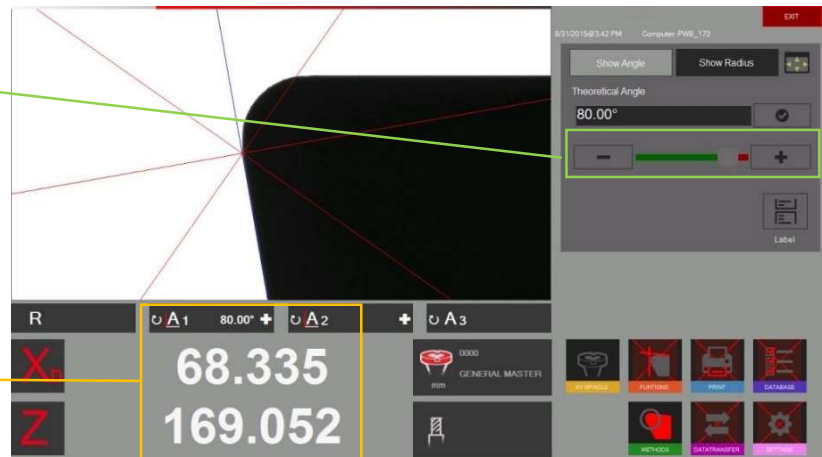

The X and Z counters indicate the cross-hairs centre position. "A1" displays the set angle.

Theoretical radius" method:

Select "Radius" in the settings window

Select "Show Radius"

For a large radius drawing (more than 6mm), with the centre in the middle of the camera's field of vision, the circumference of the circle will no longer be visible to the active camera. This chart is provided to capture the circumference and make it visible again (see examples below).

Set the value by entering it, or using "+" and "-".

Print the label

Examples with different circumference settings in the chart above:

Circle => r = 3mm

Centre

Top

Right

Using the "theoretical radius" method:

Draw a circumference (type in the values) and capture the line along the required chart (example: "Top")

Move the circumference line towards the cutting edge and...

...set the radius using the fine adjustment

The X and Z counters indicate the centre point position. "R" displays the set radius.

Top

4.7.6.9 Point measurement

The point measurement method is used to set measurement points directly in the live camera image using the mouse.



Activate the point measurement method

A selection window opens:

Point measurement type

Angle display mode

Results

Print the label

Deactivate point measurement

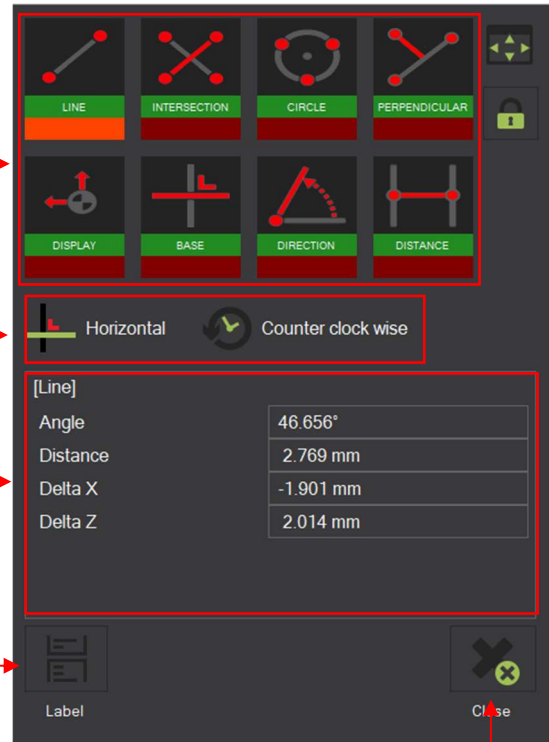

Symbols:



Point-to-point line



Angle between 2 lines, defined by 4 points



Circle measurement (defined by 3 points)



Perpendicularity between 3 points



Show/hide graphic information



Modify the angle calculation base



Change the angle direction



Distance between 2 points

Example of point measurement

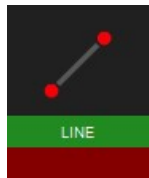

Point-to-point line

Setting measurement points 1. and 2. by clicking the mouse

Results

Angle	46.656°
Distance	2.769 mm
X	-1.901 mm
Z	2.014 mm

Angle => Line angle
Delta X => Horizontal distance between measurement points
Delta Z => Vertical distance between measurement points
Distance => Point-to-point distance



Angle between two lines

Definition of the 2 lines by 4 points

Results

[Line-Line]	
Angle 1	133.772°
Angle 2	46.707°
Angle 3	86.065°
Angle 4	93.935°
Intersection X	29.708 mm
Intersection Z	125.948 mm

The 2 lines will be defined by 4 points. Points 1 and 2 for line 1, points 3 and 4 for line 2.

When displaying graphic information, the angles can be assigned to the live image.

Results

[Line-Line]	
Angle 1	41.613°
Angle 2	133.148°
Angle 3	86.485°
Angle 4	93.535°
Intersection X	29.704 mm
Intersection Z	125.953 mm



Circle/Radius

Definition of the circle using 3 points

Results

Radius	6.029 mm
Diameter	12.057 mm
Center X	24.743 mm
Center Z	133.885 mm



Perpendicularity between 3 points

Definition of the circle using 3 points

Results

[Line-Line]	Distance	1.580 mm
-------------	----------	----------



Distance between 2 points

The screenshot displays the EyeRay® Quadra software interface. The main workspace shows a vertical line with two points marked. A horizontal dimension line between these points is labeled "X: 1.941 mm". The software's top status bar shows "EyeRay® Quadra V3.11.0.0 EN" and "6/30/2023@2:56 PM Computer: EVOSET-PC User: ADMINISTRATOR Evoset AG". A toolbar on the right contains icons for LINE, INTERSECTION, CIRCLE, PERPENDICULAR, DISPLAY, BASE, DIRECTION, DISTANCE, ETIQUETTE, and ECLAIRAGE. Below the toolbar are options for "Horizontal" and "Counter clock wise". An "Information" panel is also visible. The bottom control panel includes axes (R, X_R, Z), coordinate inputs (A1, A2, A3), and tool selection (02 mm FANUC - CTX16, 1000 FANUC - CTX16). Additional icons for FUNCTIONS, PRINT, DATABASE, METHODS, DATATRANSFER, and SETTINGS are located in the bottom right corner.

4.7.7 Select the axis measurement/counter display mode

The measurement result is shown under the camera image in the results area. Results such as X and Z axis values, radii and angles are displayed.

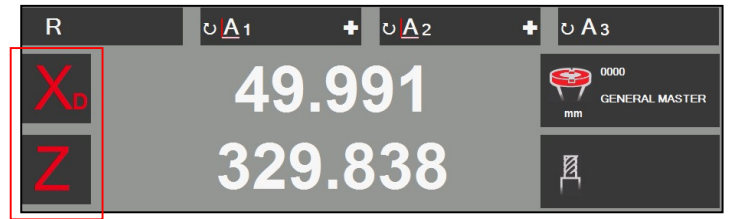

Clicking on X and Z opens a pop-up window in which the different "axis measurement modes" can be selected.

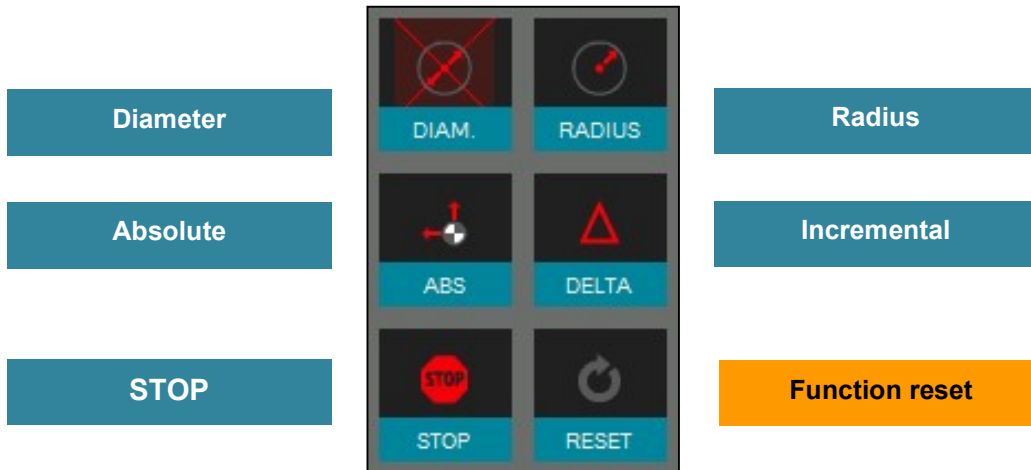

The "Set Standard" key will display the value as defined with the "reference point".



In incremental mode, the selected axis will be set to "0.000" and the colour will change to blue. The mode will also be indicated by the small icon next to the axis name.

"Absolute" X mode

"Incremental" Z mode

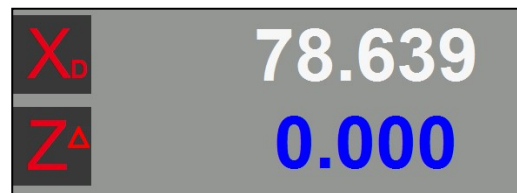

In "STOP" mode, the value of the selected axis is frozen and the colour becomes light grey. The mode will also be indicated by the small icon next to the axis name.

"Stop" X mode

"Absolute" Z mode

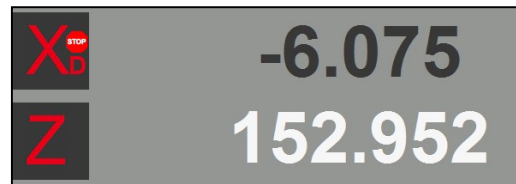

The measured angles and radii will be displayed over the counter values and are described below:



Click the '+' sign to open a window in which the angle calculation base and measurement angle direction can be modified.

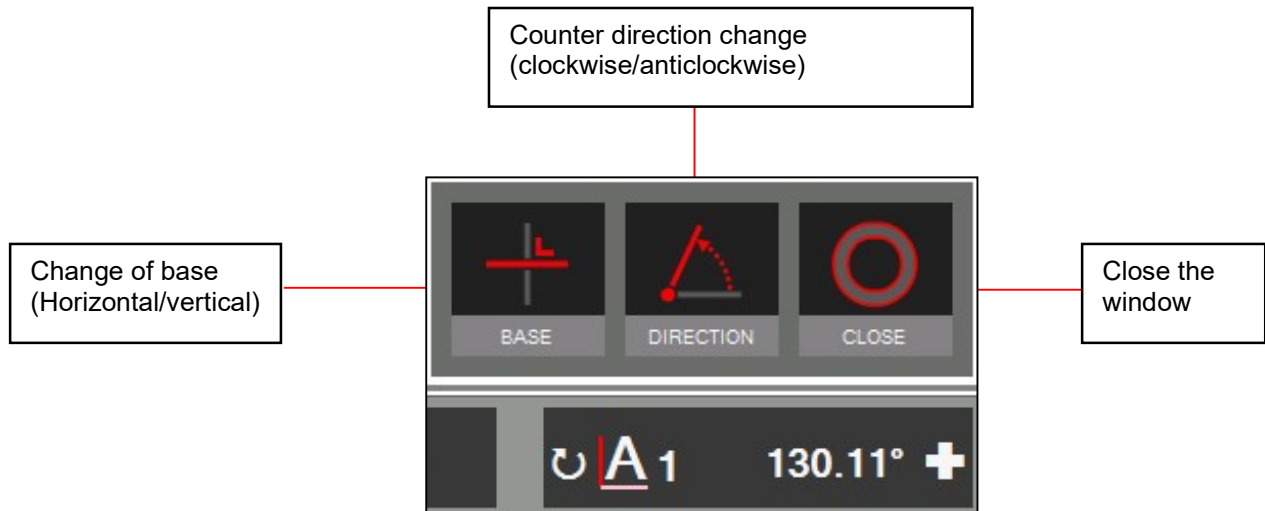

Examples:

1)

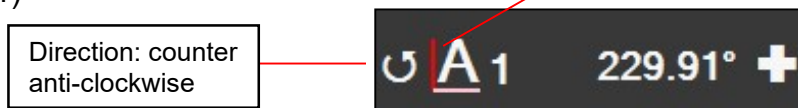

2)

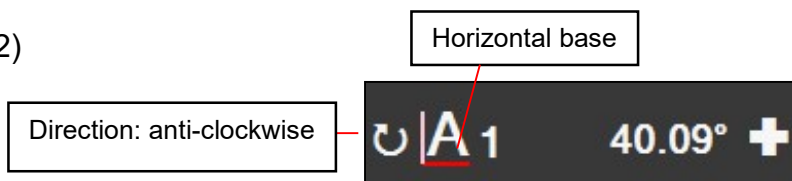

By clicking on A1 or A2, the corresponding line in the image will be displayed in green for a few seconds.

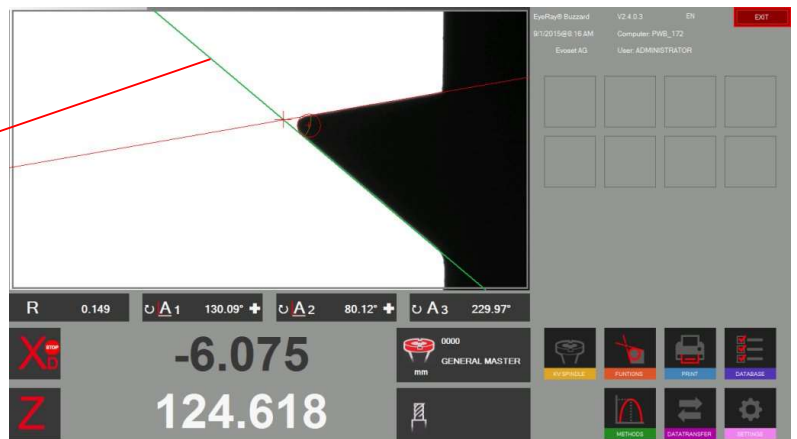

4.8 Printing the measured values



Click this icon to display the installed print options.

4.8.1 Printing standard labels



Click this icon to print a label on the label writer.

4.8.2 EyeRay® custom label printing, **option**



A second label format can be customised to customer specifications. On request.

Evoset/PWB item number: P270540
See section "5.3 EyeRay® custom labels".

4.8.3 EyeRay® report printing, **option**

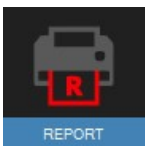

Available soon: Report printing to customer specifications.

Evoset/PWB item number: P270550
See section "5.2 Printing EyeRay® reports".

4.8.4 Changing label size

To change the label size on the Brother QL800

Open PARAMETERS / DEVICES / PRINTERS AND SCANNERS
Go to MANAGE / PRINTER PROPERTIES
Click PREFERENCES
Choose PAPER FORMAT 62mm
Then **simply** adjust **the width**, for example 40mm
Then APPLY

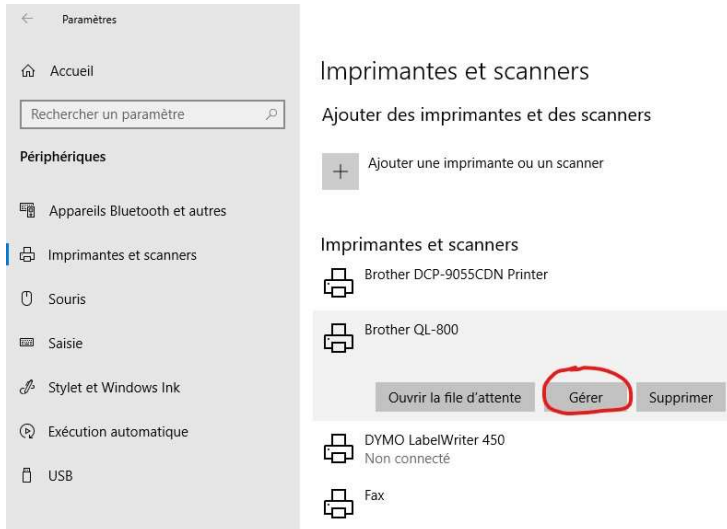

Brother QL-800

Gérer votre appareil

État de l'imprimante : Inactif

Ouvrir la file d'attente d'impression

Imprimer une page de test

Exécuter l'utilitaire de résolution des problèmes

Propriétés de l'imprimante

Préférences d'impression

Propriétés du matériel

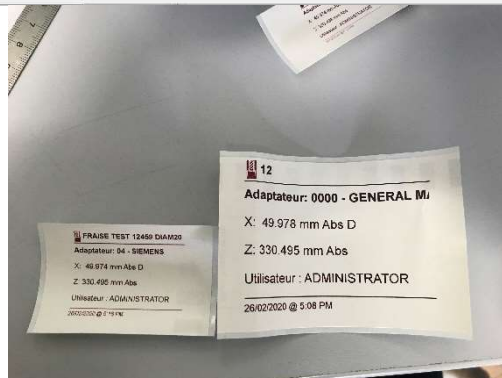
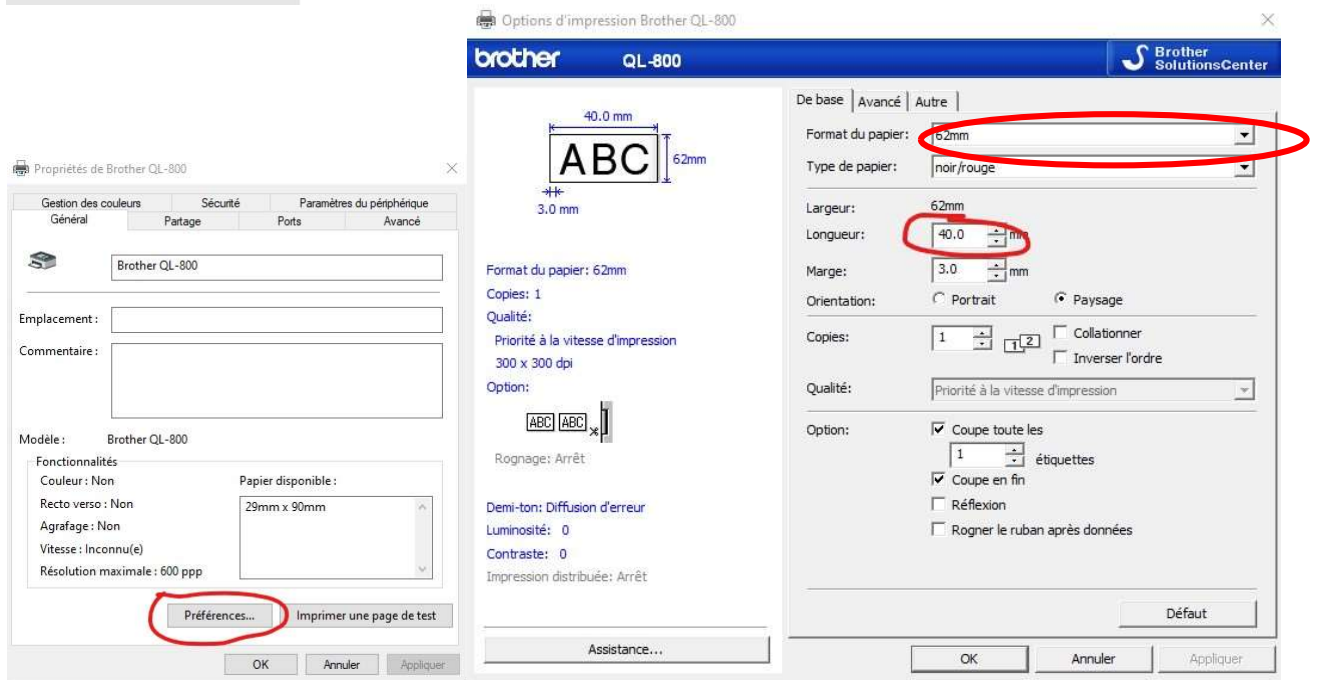

4.9 Data transfer

4.9.1 List of tools

This function is used to generate and save a list of tools for each part to be produced.



Tool list management is in the "Transfer" menu

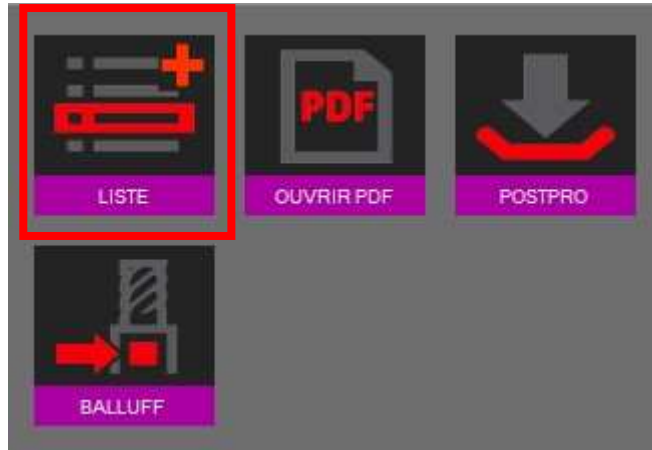

The measurement list icon is multifunctional:

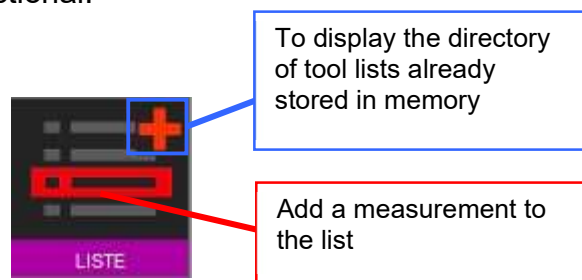

Click in the red box in the list of tool icons to add a measurement to the list.

The following can be added: Tool number / Magazine number / Tool name (configurable input field)



Confirm with



Cancel with



Click the "+" button in the list of tool icons to display the list.



N° d'outil	Nom de l'outil	Numéro d'opération	N° de magasin	Valeur X	Valeur Z	Angle 1	Angle 2	Angle 3	Rayon
12	TEST	1	12	16.290	391.858	0	0	0	0
14	TEST2	1	14	16.290	391.858	0	0	0	0

Toolbar icons: Ajouter, Supprimer, Rafraichir, Effacer, Ouvrir, Enregistrer, Liste, Postpro, Bailuff, Fermer

Functions:



Add a new measurement to the list



Delete the highlighted list of measurements

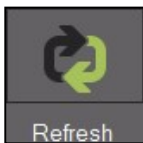

Re-measure the highlighted measurement

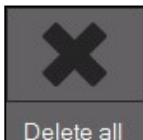

Delete the list of tools



Open the tool list directory

A tool list that has already been created can be loaded in this way.

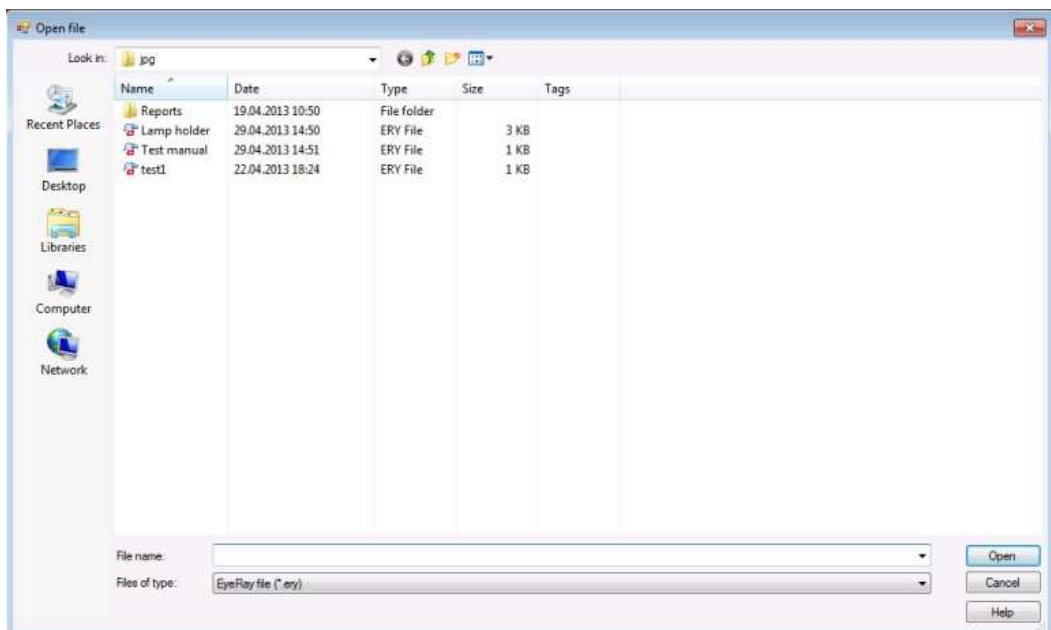



Save the list of tools

Save the list of tools in the directory

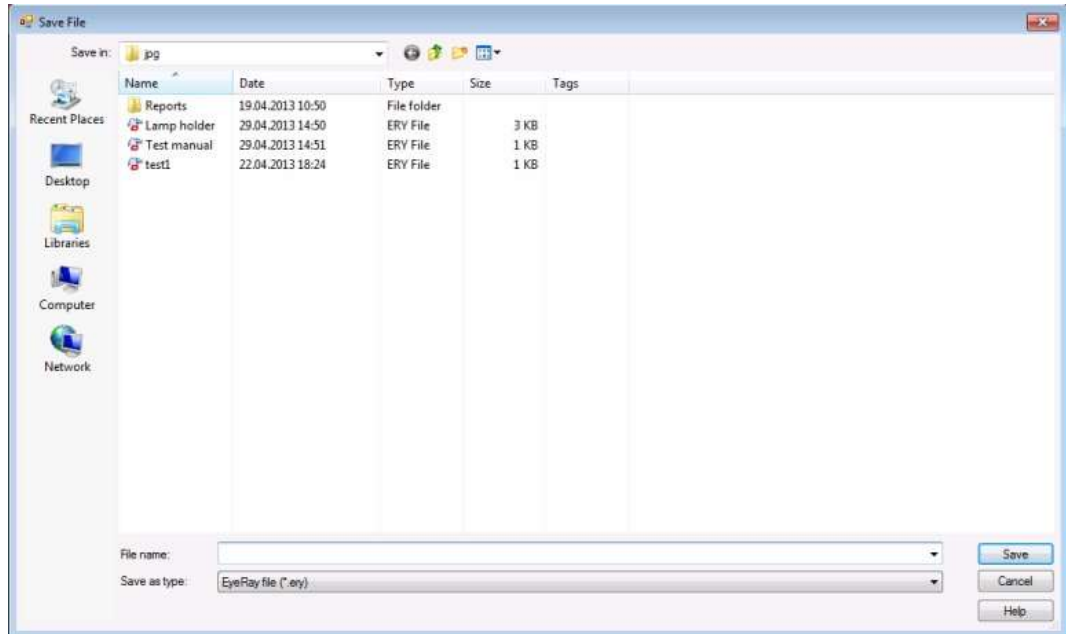

To print the list on a printer (A4 format must be installed and configured in the printer settings, otherwise a PDF file is created by default).

Default (PDF):



A window opens:

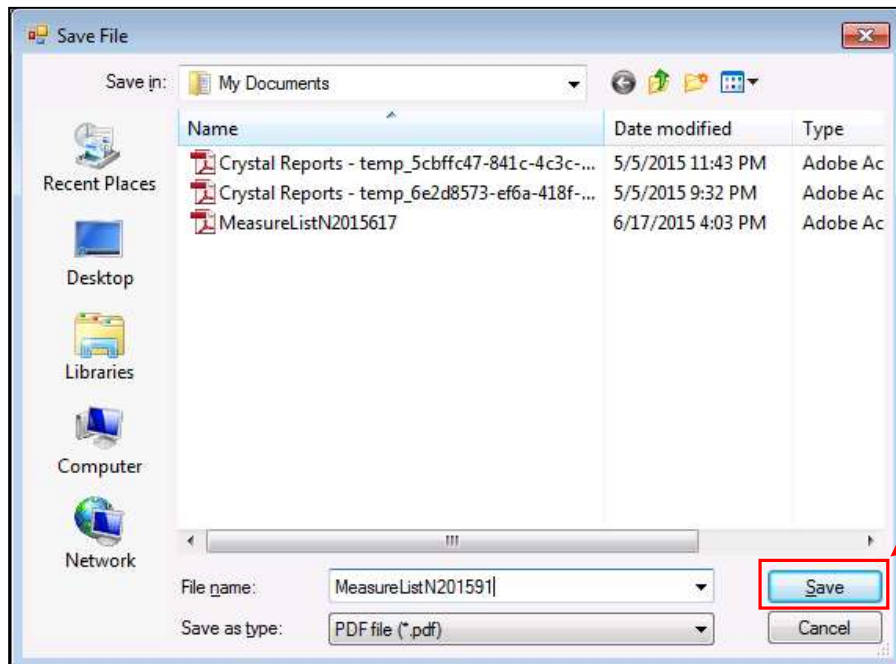

Save the file as a PDF

After saving, the file will automatically be opened



Evoset AG
Alustrasse 18.

CH-3940 - Steg - Switzerland
Tel: +41 27 922 0450
service@evoset.com
www.evoset.com

Liste der Messungen

Datum 3/3/2022

Bezugspunktname 0000 GENERAL MASTER

Werkzeug Nr.	Werkzeugname	Schneide	Magazin Nr.	X	Z	A1	A2	A3	R
1		1	1	29.991	91.100	0	0	0	0
2		1	2	29.991	91.101	0	0	0	0
3		1	3	29.374	90.887	0	0	0	0



Close the tool list



PostPro generation of gauge files in NC format
(See section 5.4) option



Export tool values to the Balluff chip interface
(SEE section 5.5) option

4.9.2 Open a PDF file



Use this icon to open PDF files saved as measurement lists or reports.

A window opens, from which the system to open can be selected, PDF files can be renamed and moved to other directories, such as a USB thumb drive, or files can be deleted.

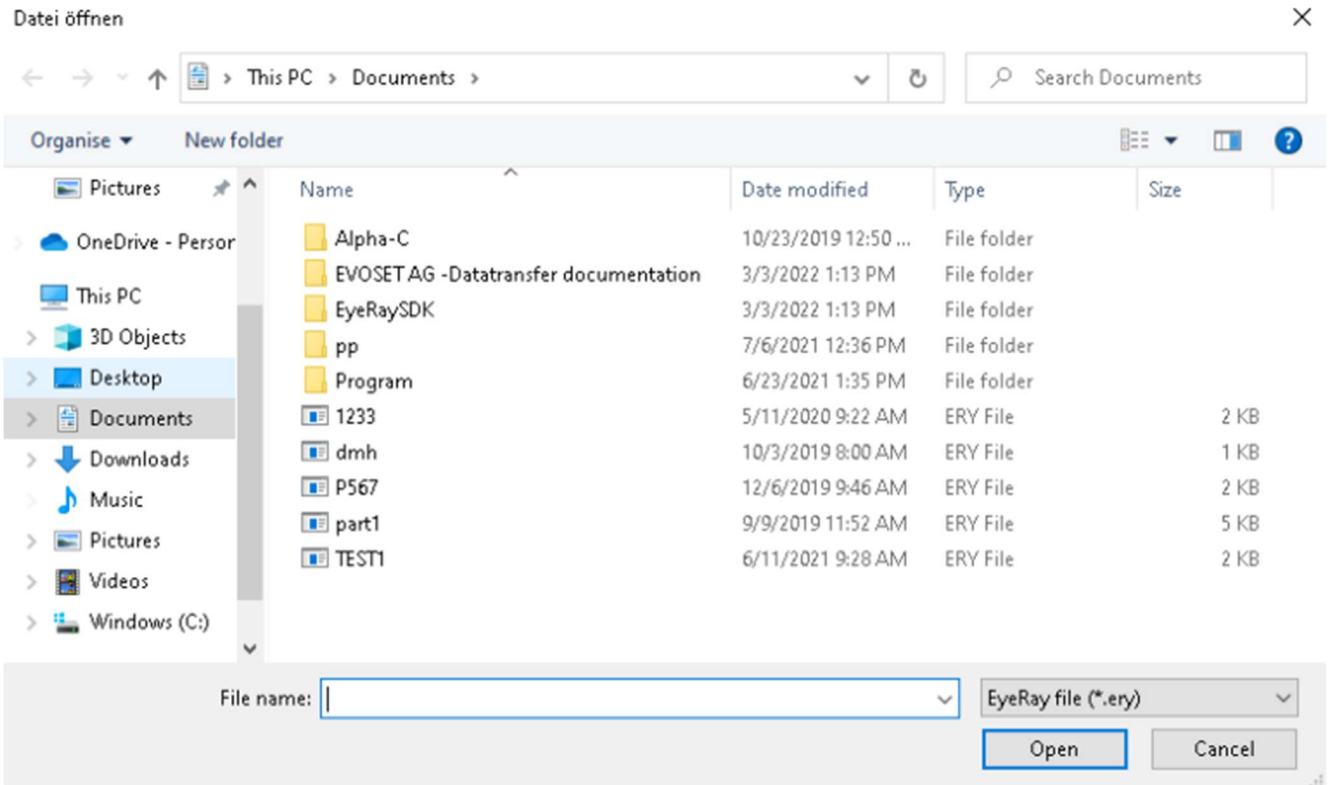

4.9.3 Post Processors



PostPro generation of gauge files in NC format
(See section 5.4) **option**

Generate an offset file using EyeRay and send it to a network or local folder ↔
Transfer using DNC software or another system such as a USB thumb drive ↔

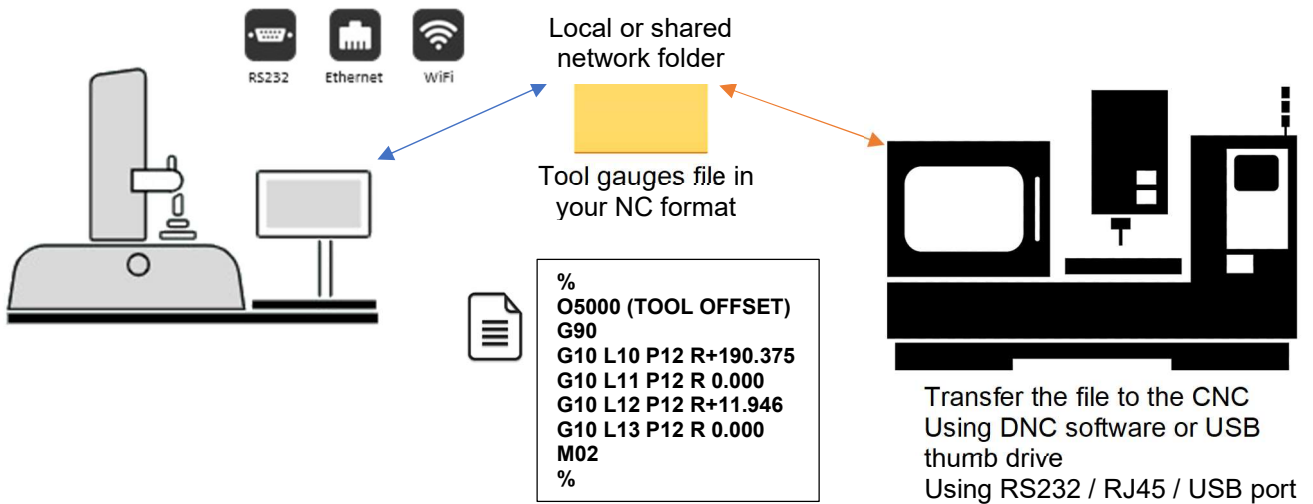

Add a tool from the measurement list



N° d'outil	Nom de l'outil	Numéro d'opération	N° de magasin	Valeur X	Valeur Z	Angle 1	Angle 2	Angle 3	Rayon
12	TEST	1	12	11.946	190.375	0	0	0	0



Click the POSTPRO button

A message appears with the output file path
It can be installed locally on the PC or on the customer network
This is entirely configured to the customer's requirements

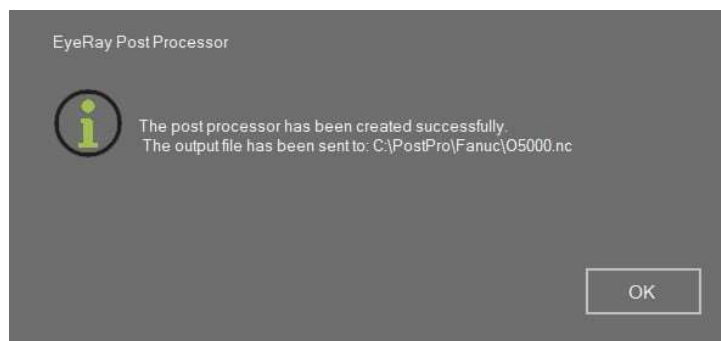

4.9.4 Balluff chip read/write system



Balluff interface access

Balluff HMI example with MCM mapping



Read data from the Balluff chip



Measure the tool in EyeRay



Write data to the Balluff chip



Initialise the chip with the mapping format and default values

4.9.4.1 Measure a tool with a Balluff chip



Click on the MEASUREMENT button to exit the Balluff HMI and go back to EyeRay
Then position the tool and measure it

Then click the LIST button



The list appears: select the required cutting edge

N° d'outil	Nom de l'outil	Numéro d'opération	N° de magasin	Valeur X	Valeur Z	Angle 1	Angle 2	Angle 3	Rayon
1		1		0	0				
2		2		0	0				
3		3		0	0				
4		4		0	0				
5		5		0	0				

Click REFRESH

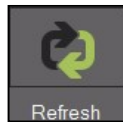

The measurement list is updated with the tool values

N° d'outil	Nom de l'outil	Numéro d'opération	N° de magasin	Valeur X	Valeur Z	Angle 1	Angle 2	Angle 3	Rayon
1		1	1	11.946	174.765	0	0	0	0
2		2		0	0				
3		3		0	0				
4		4		0	0				
5		5		0	0				

Click  to go back to the Balluff interface

The values are now updated in the required cutting edge

Cutting Edge 1	Cutting Edge 2	Cutting
Longueur Parametre 1	174.765	
Rayon Parametre 1	11.946	

Click  a message is displayed to confirm the write to the chip

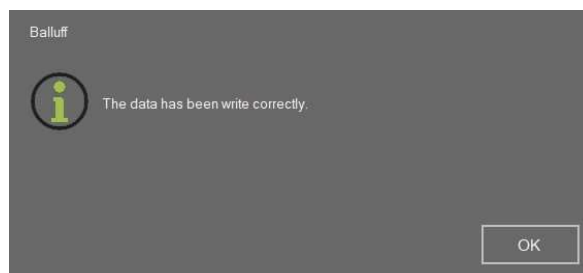

4.9.4.2 Initialise a chip



Click the INITIALISE button to set the chip values to zero
Formatting a new chip to mapping format.

A chip initialisation message appears

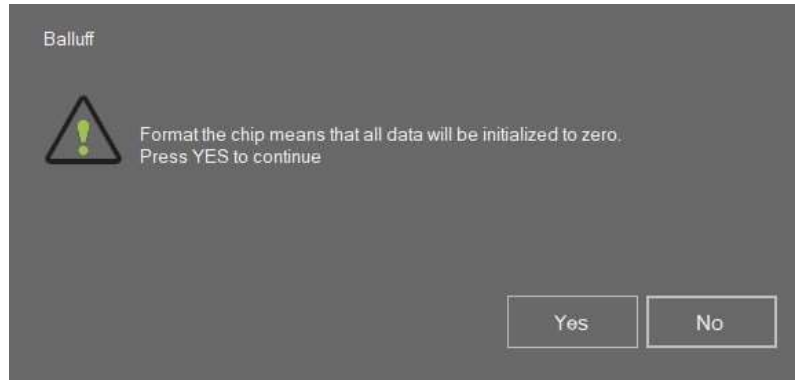

4.10 Database



This icon activates the database functions.

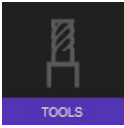

Tool database

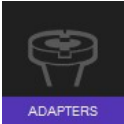

Open the reference points database



Backup or restore icon

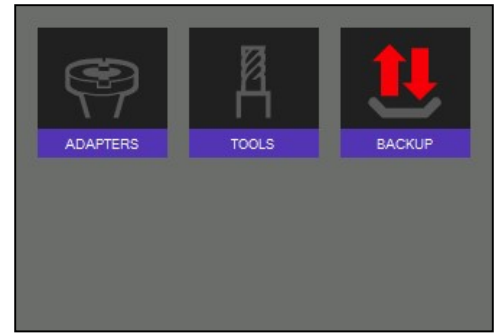

4.10.1 Reference point database

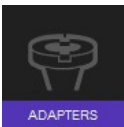

Click this icon to activate the reference point database.

The first adapter/reference point is always the General master used to calibrate the unit. It always bears the number "0000" and cannot be deleted.

This is what is referred to as an "absolute point zero" with which the unit will be calibrated.

N° Adapter	0000	<input checked="" type="radio"/> mm	<input type="radio"/> inches
Name	GENERAL MASTER	<input checked="" type="radio"/> Diameter	<input type="radio"/> Radius
Creation date	11/9/2012	<input checked="" type="radio"/> Reference value	<input type="radio"/> Offset value
Notes		<input type="checkbox"/> Axes reversed	<input type="checkbox"/> Mirror X
Image		X	49.985
		Z	329.83

Navigation: Previous, Next, Search, New, Modify, Delete, Keyboard, OK, Cancel

The "0000" reference point cannot be modified.

4.10.1.1 Input field description:

Information:

Adapter number	Reference point number
Name	Description of the reference point (name of the system owner machine)
Creation date	Defined automatically
Notes	Remarks
Image	Click in this area and browse the computer to add an image to the reference point.

Options:

mm inches

Defines the reference point unit

Diameter Radius

Result of the radius diameter measurement

Offset value

Standard setting: The offset value is the difference between the master mandrel point zero (General Master) and the point zero of the tool holder for the tool being used.

Mainly used.

Referred to as: offset/relative point zero.

Reference value

It is possible to have other absolute point zeroes alongside the master mandrel (General Master). The nominal values must be entered in the input fields for "X" and "Z".

Referred to as: absolute/reference point zero

Axes reversed

The vertical axis will become the X axis and the horizontal axis will become the Z axis.

Mirror X

Mirror Z

Changes the axis counting direction

X	0	
Z	15.42	

Input field for the "X" and "Z" values
Enter the offset or reference values according to the settings made above.

Axis description: to enter an axis name. The axis will be displayed here once specified => example: replace the description of the X axis by axis A.

Most of the time it is the Z-axis offset value that is entered here (values engraved on the PWB adapter).

If the reference point is "inverted axes": define which axis the R/D measurement mode should be activated on.

If the axes are not inverted, the R/D mode is on the X axis.

Functions:



Browse the database from one reference point to the next



Search the databases for a specific reference point



Add a new reference point



Save the changes



Delete the reference point



Display the "virtual keypad"



Select the adapter



Close the list

4.10.1.2 Examples of reference points:

1.)

Reference point N°: 63

Reference point of a machine with the HSK-A63 tool holder system.

- Offset values:

X = 00.00 mm

Z = 15.57 mm

The screenshot shows a software interface for configuring a reference point. On the left, there are input fields for 'Bezugspunkt Nr.' (10), 'Beschreibung' (HSK 63), and 'Erstelldatum' (3/11/2016). Below these is a 'Notizen' field and a 'Bild' field containing a placeholder image icon. On the right, there are radio buttons for units (mm selected), diameter (selected), absolute (selected), and offset value (selected). There are also checkboxes for 'Achsentausch', 'Priorität', 'Sperren', 'Zählrichtung X tauschen', and 'Zählrichtung Z tauschen'. Below these are input fields for X (0) and Z (15.42). At the bottom, there is a row of navigation icons: 'Vorheriger', 'Nächster', 'Suchen', 'Neu', 'Ändern', 'Löschen', 'Tastatur', 'OK', and 'Abbrechen'.

2.)

Reference point N°: 400

Reference point of a machine with the VDI40 tool holder system.

- Inverted axes
- Count direction switched to the Z axis.
- R/D mode active on the X axis.
- Offset values:

X = 00.00 mm

Z = 35.55 mm

The screenshot shows a software interface for configuring a reference point. On the left, there are input fields for 'Bezugspunkt Nr.' (100), 'Beschreibung' (VDI 30), and 'Erstelldatum' (3/11/2016). Below these is a 'Notizen' field and a 'Bild' field containing a placeholder image icon. On the right, there are radio buttons for units (mm selected), diameter (selected), absolute (selected), and offset value (selected). There are also checkboxes for 'Achsentausch', 'Priorität', 'Sperren', 'Zählrichtung Z ändern', and 'Zählrichtung X ändern'. Below these are input fields for Z (0) and X (30.35). The Z and X input fields have green status bars next to them that say 'R/D Modus eingeschaltet'. At the bottom, there is a row of navigation icons: 'Vorheriger', 'Nächster', 'Suchen', 'Neu', 'Ändern', 'Löschen', 'Tastatur', 'OK', and 'Abbrechen'.

4.10.2 Backup and restore

The backup procedure saves the EyeRay® system databases. All the adapters, tools (units with tool database), correction and calibration data (size in pixels, etc.) will be saved in a backup file.



This icon opens the backup and restore functions.

Icon description:

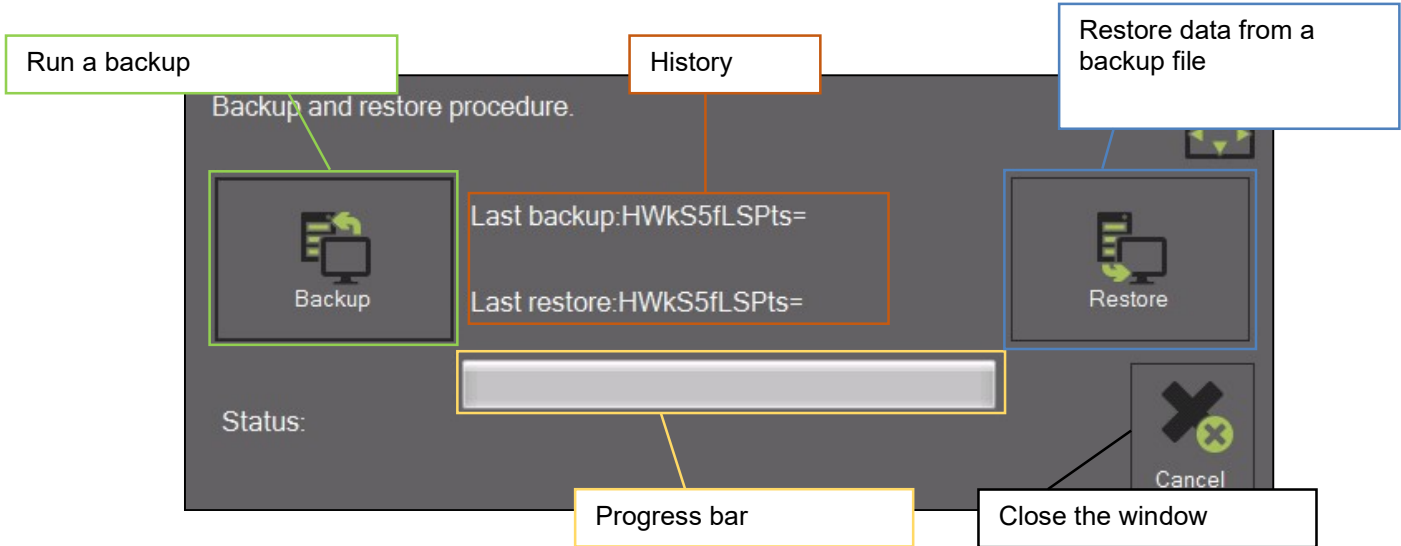

Backup operations:

Activate the procedure using the icon on the right:



It opens a window used to select the backup directory:

Create a folder, name it "backup" and start the procedure by pressing "OK"

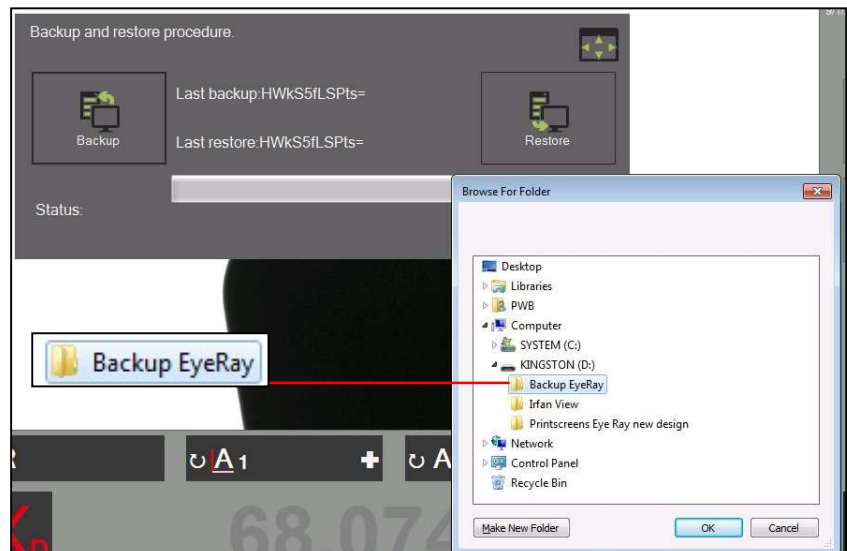

The backup must be made on a USB thumb drive and not on the PC itself!

The bar shows the backup progress. This operation can take several minutes.

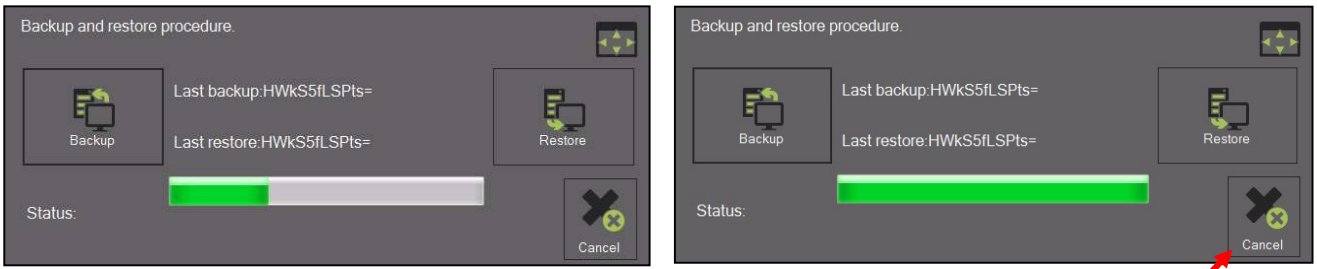

Close the window after completing the backup procedure.

Restore:

Activate the procedure using the icon on the right:

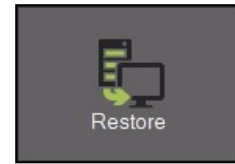

Select the backup file to be restored.

Select the "EyeRayBackup... .. .bak" file and start the restore process by clicking "Open".

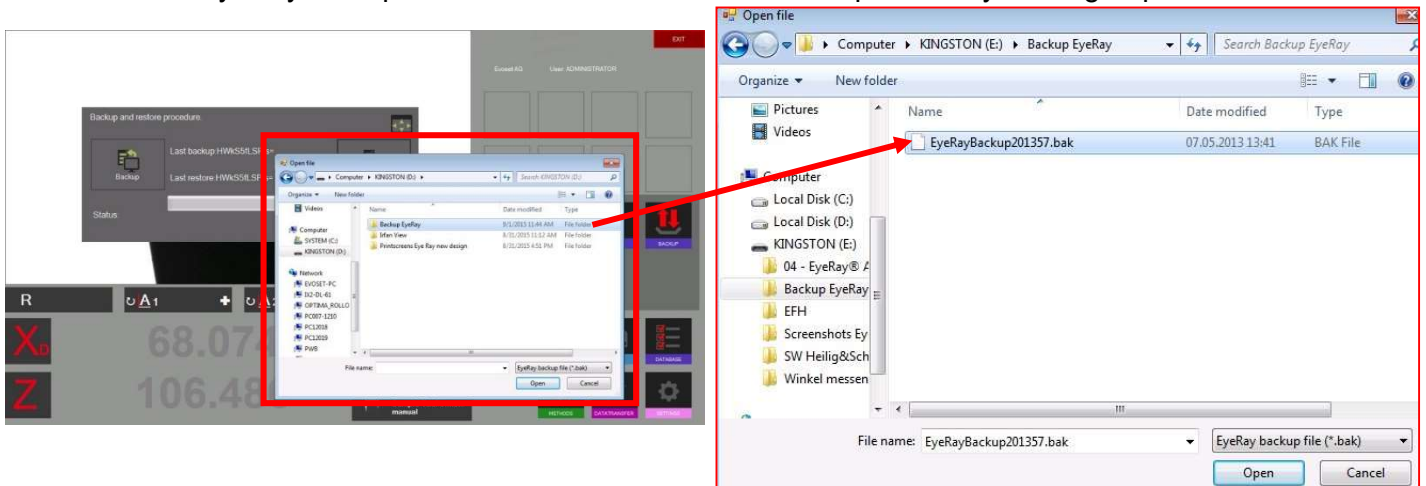

The bar shows the backup progress. This operation can take several minutes.

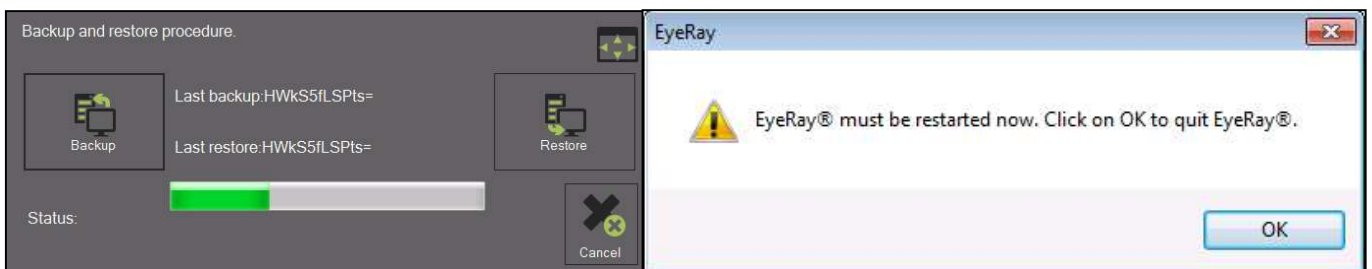

Once the restore operation is complete, the system must be restarted.

5 Optional functions

5.1 KV spindle operation

KV spindle functions are controlled by the EyeRay® software.



Open the spindle function menu by clicking this icon.

A window appears showing the available spindle functions.

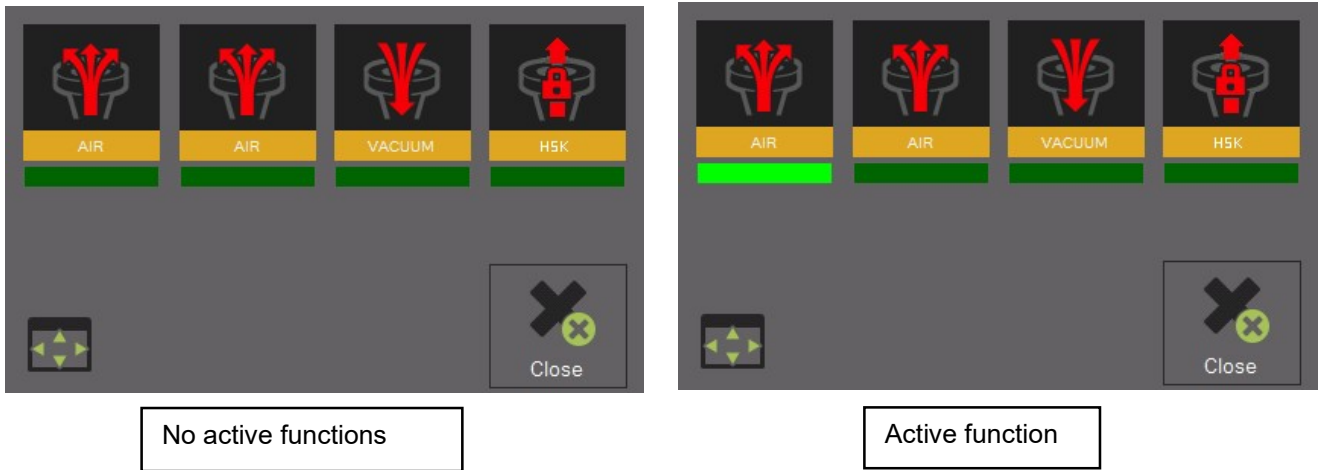

The activation of a function is indicated by the bright green bar under the icon.

Functions:



Rotation block



Air ejection



Vacuum clamping



HSK Pull- in=> Not available on TM Quadra machines

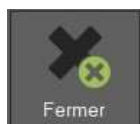

Close the spindle function window

5.2 Print a report (software option)

Print a custom measurement report.

Element number: P270550/Report print

5.3 EyeRay® custom label print (software option)

Custom label print

Element number: P270540/EyeRay® custom label

5.4 EyeRay® Postpro data transfer (software option)

Data transfer to a network or machining centre. Several post-processors are possible.

Element numbers: P270220/EyeRay® License Data Transfer
P270215/EyeRay® PostPro Data Transfer/Per Order

5.5 RFID chip/EyeRay® data transfer (software option)

Data transfer by data medium to tool support (RFID chip).
Several possible mappings.

Element number: P270225 (contains the software/licence and hardware for the Tool Master)

5.6 Centre height measurement with camera/EyeRay® (option)

Centre height measurement using a second camera (horizontal camera).
The camera can be fitted at a later date and is assembled on the Tool Master side plate.

Element number: P270110/Centre height measurement using EyeRay® camera

5.7 EyeRay® tool management (option for SW)

Tool database with several functions such as: link to a MF/tolerance setting, several cutting edges possible per tool, work with nominal values, link to images, creation of tooling sheets, etc.

Element number: P270570/EyeRay® Tool Management

5.8 Custom measurement function (software option)

Measurement function based on specially created specifications.







Element number: P270590/

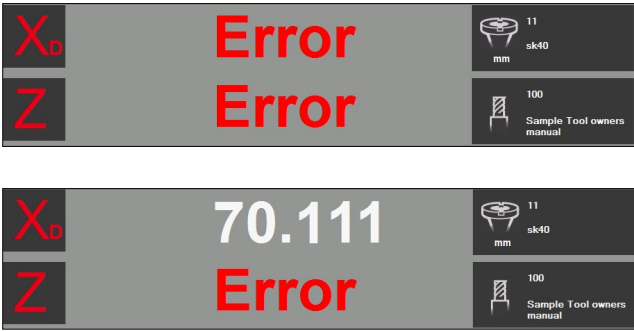
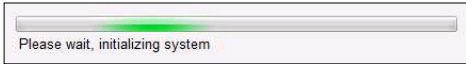
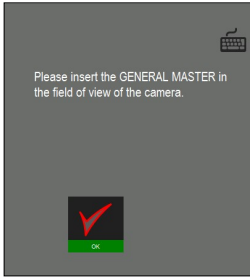
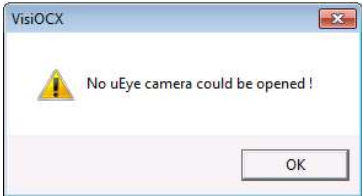

5.9 Excel and EyeRay® link (software option)

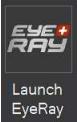
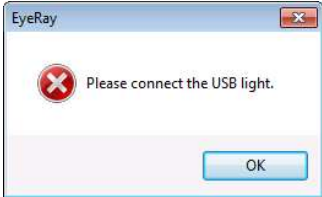

To save a list of measurements to an Excel file.
Note: Excel must be purchased and installed by the Tool Master owner.

Element number: P270560

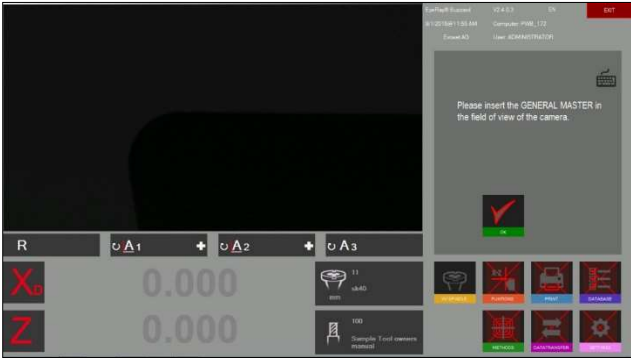
6 Solution

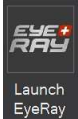
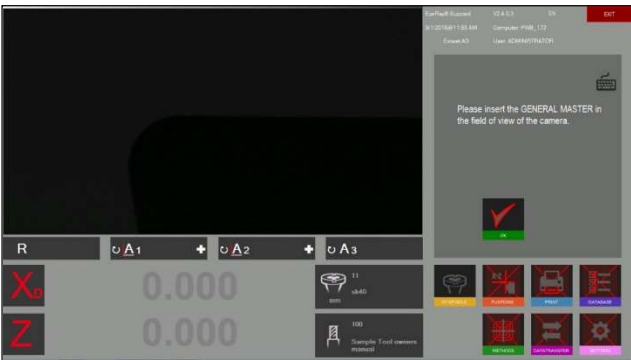
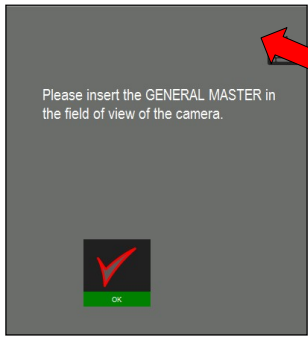
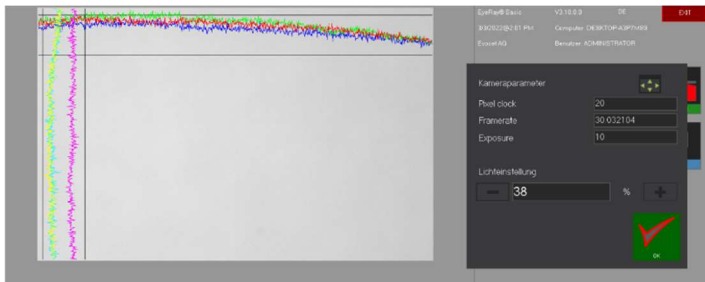
Problem	Solution
<p>(1) Error on axis X and/or Z</p>  <p>Note: This Error can occur when a USB flash drive is disconnected from the computer.</p>	<p>1.) Check the USB connection between the PC and the TOOL MASTER.</p> <p>2a.) Disconnect the USB connection between the PC and the TOOL MASTER and reconnect it after a few seconds.</p> <p>2b.) This will initialise the system.</p> <p>2c.)</p>  <p>2d.) The device must then be calibrated.</p> 
<p>(2) “No uEye camera could be opened!” message (uEye cameras cannot be opened) when the EyeRay® software was launched.</p> 	<p>1.) Check the USB connection between the PC and the TOOL MASTER.</p> <p>2a.) After logging in, close the EyeRay® software by clicking on the red button (top right).</p>   <p>2b.) Restart the EyeRay® software.</p>
<p>(3) “Please connect the USB light” message when launching EyeRay® software</p> 	<p>1.) Check the USB connection between the PC and the TOOL MASTER.</p> <p>2.) Check that the main switch at the back of the TOOL MASTER is closed (ON).</p>  <p>3a.) After logging in, close the EyeRay® software by clicking on the red button (top right).</p>  <p>3b.) Restart the EyeRay® software.</p> 

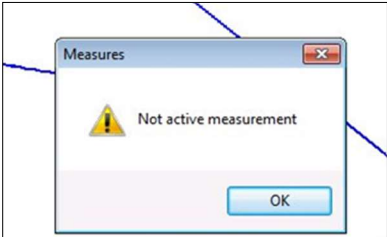
Problem	Solution
<p>(4a)</p> <p>Blue screen after launching the EyeRay® software.</p> 	<p>1.) Check the USB connection between the PC and the TOOL MASTER.</p> <p>2.) Check that the main switch at the back of the TOOL MASTER is closed (ON).</p>  <p>3a.) Close the EyeRay® software by clicking on the red button (top right).</p>   <p>3b.) Restart the EyeRay® software.</p>
<p>(4b)</p> <p>The blue screen is still there after launching the EyeRay® software (point 4a) already carried out).</p> 	<p>1.) Open the "calibration light" by pressing Ctrl and L <u>one after the other</u></p> <p>If no keyboard is connected, open the virtual keypad by clicking the keyboard key in the blue calibration window.</p>  <p>Note: On the virtual keypad, click the Ctrl key twice before clicking the L key.</p> <p>2.) Change the "light setting" value until all the lines are inside the two tolerance zones.</p> 

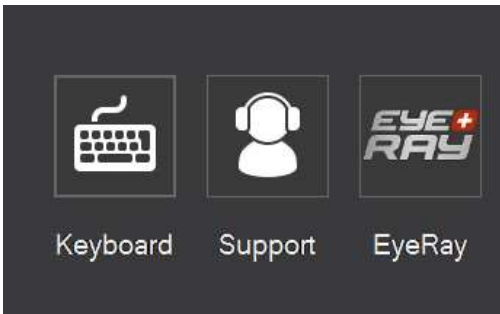
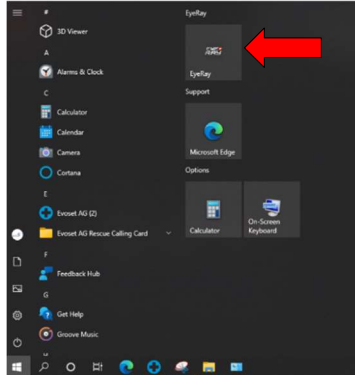
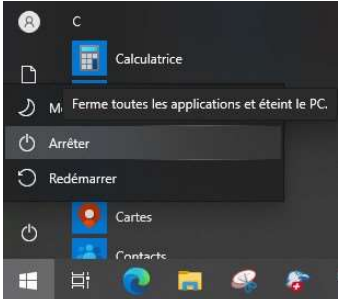
Problem	Solution
<p>(5a)</p> <p>The unit cannot be calibrated. The following message appears:</p> 	<p>Position the mandrel in the camera's field of vision.</p>
<p>(5b)</p> <p>There is no measurement line to calibrate the device. The message "No active measurement" is displayed.</p> 	<p>1.) Start the light calibration and light intensity check. ⇒ Follow point (4b)</p> <p>2.) The device can now be calibrated.</p>
<p>6)</p> <p>The EyeRay® start menu <u>is not</u> displayed.</p> 	<p>Restart the EyeRay® software by clicking the EyeRay® icon in the Windows® start menu</p>  <p>Power off or Restart the PC from the Windows®</p>  <p>Start menu</p>

(7)

The following message appears on start-up:

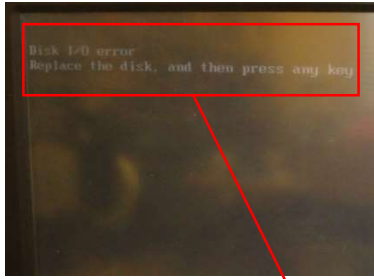

Disk I/O error
Replace the disk, and then press any key

A USB storage device is inserted in the PC.
Remove the USB thumb drive and switch on
the PC.

7 Diagrams

7.1 Overview of the TM Quadra connections

= USB Connections



= 24V Connections



=100-240 VAC Connections

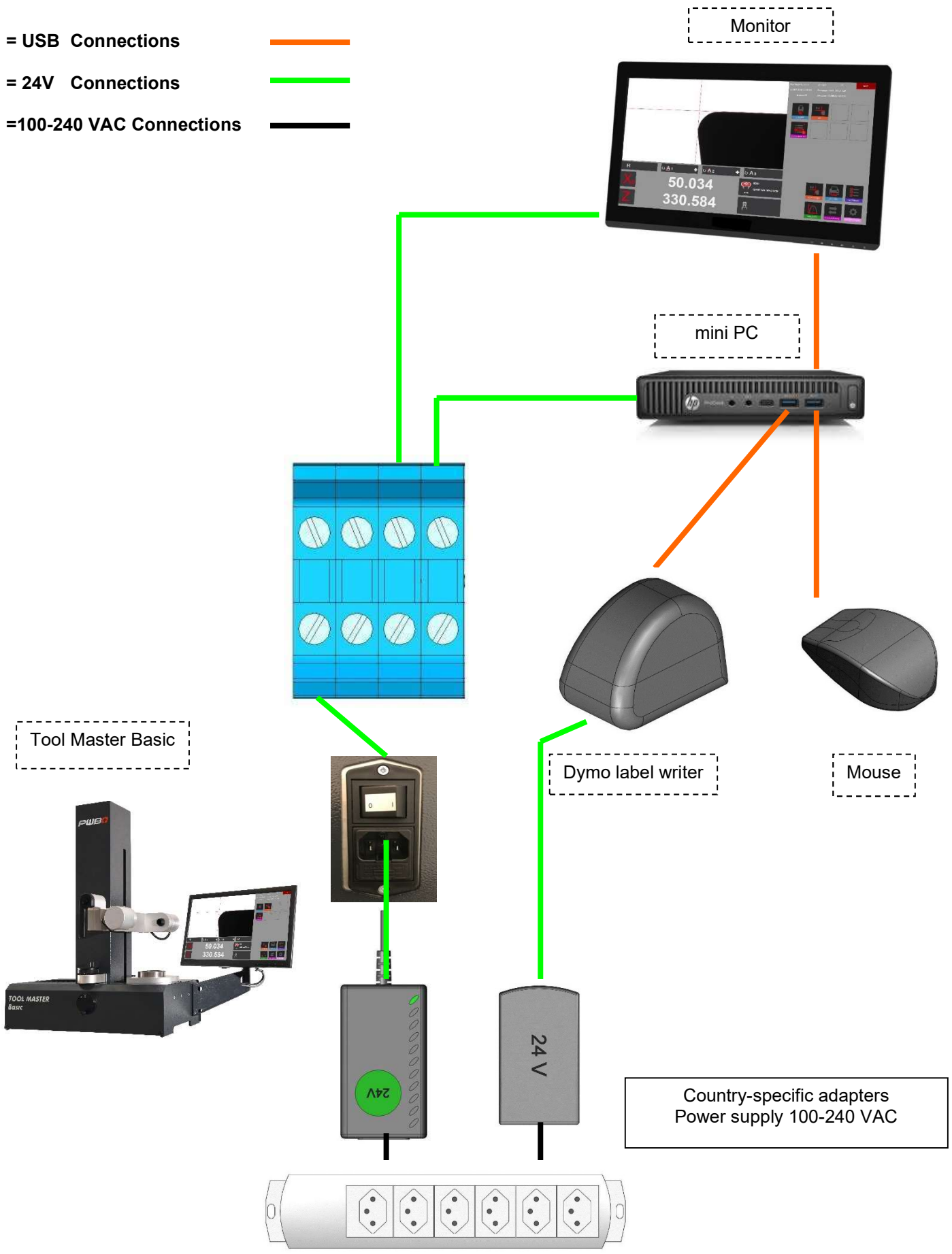

7.2 USB hub/needle bearing connection

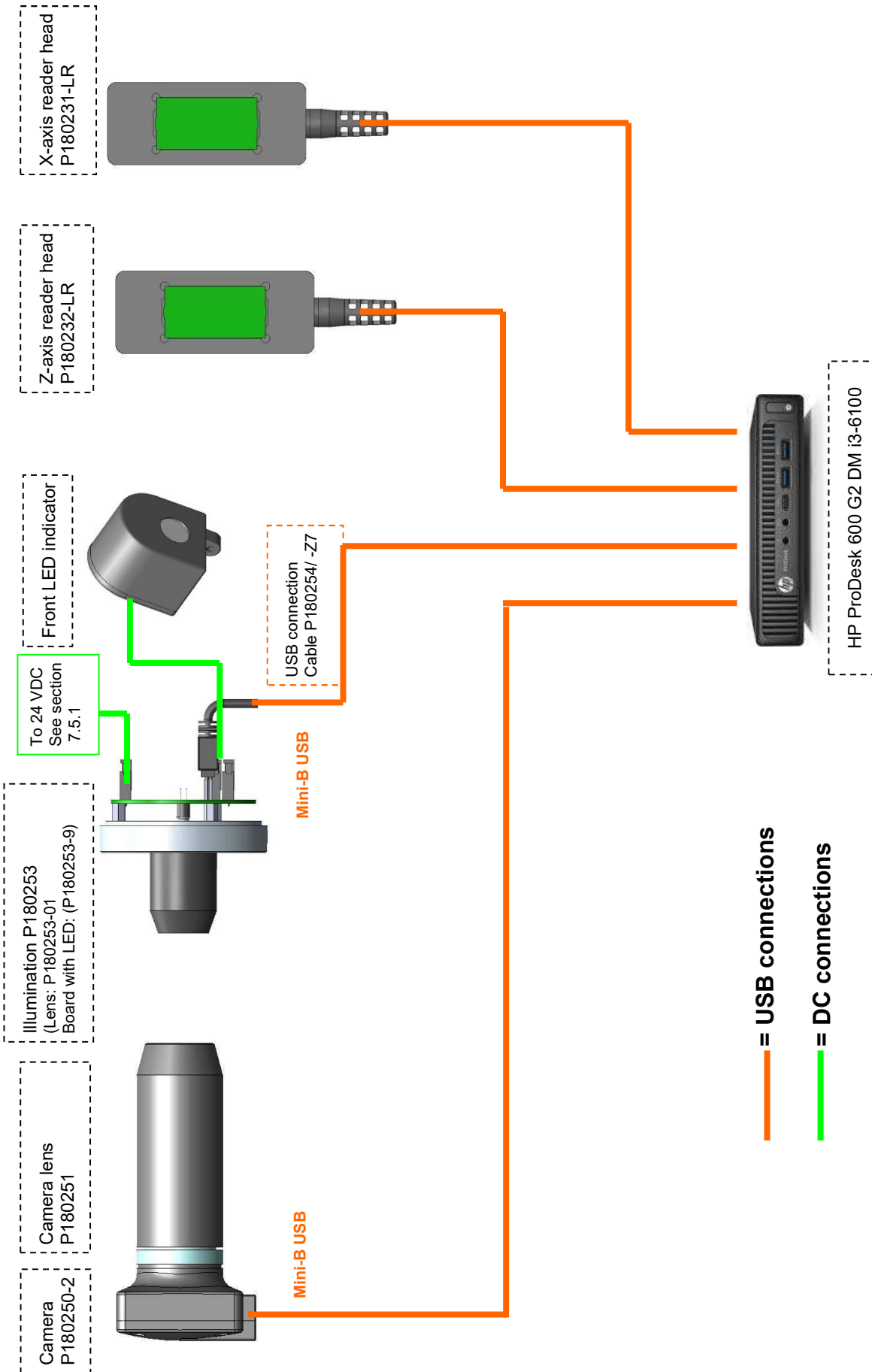

7.3 USB hub/KV spindle connector

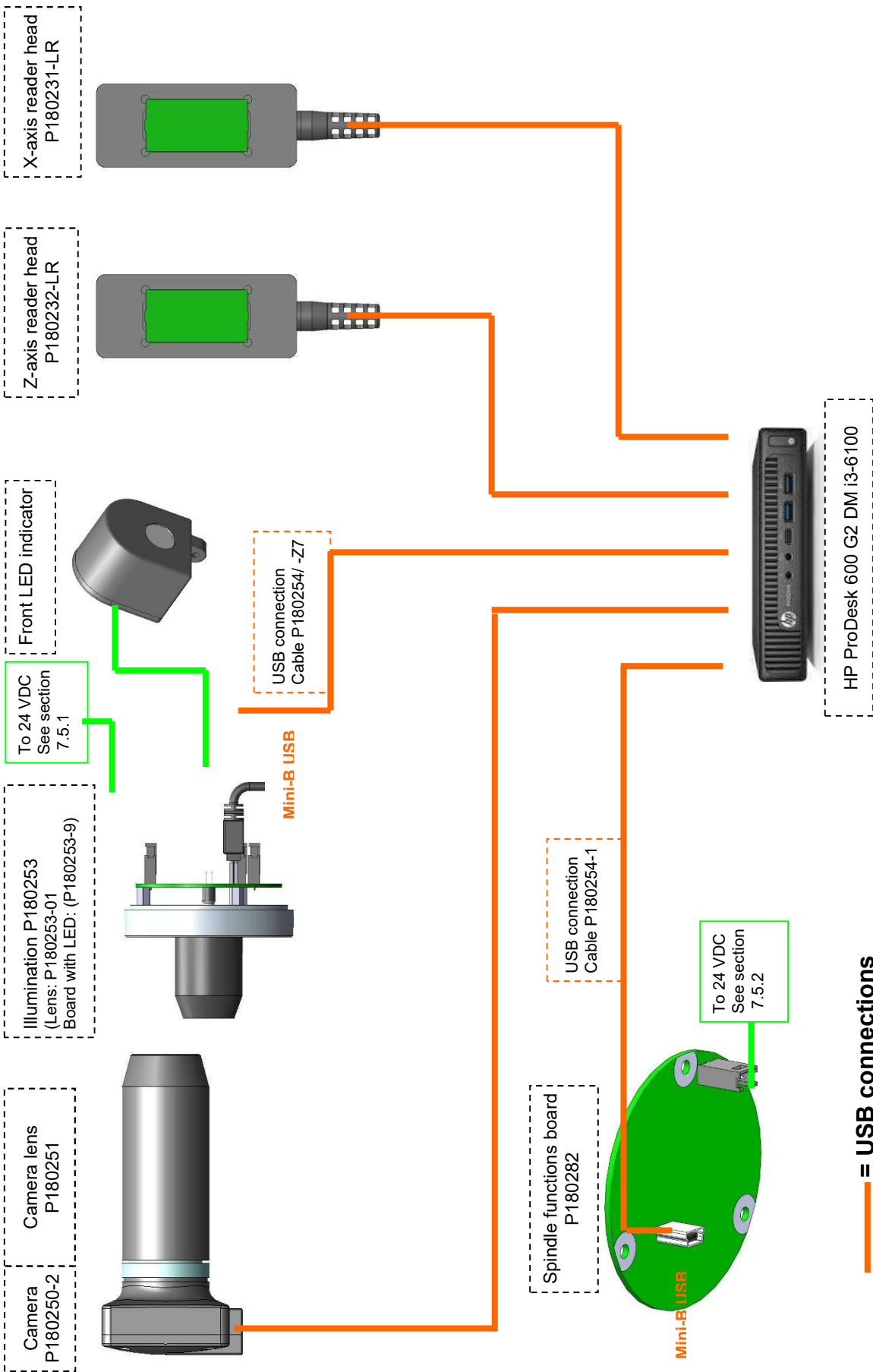

7.4 Pneumatic connections

7.4.1 Tool ring: Needle roller bearing

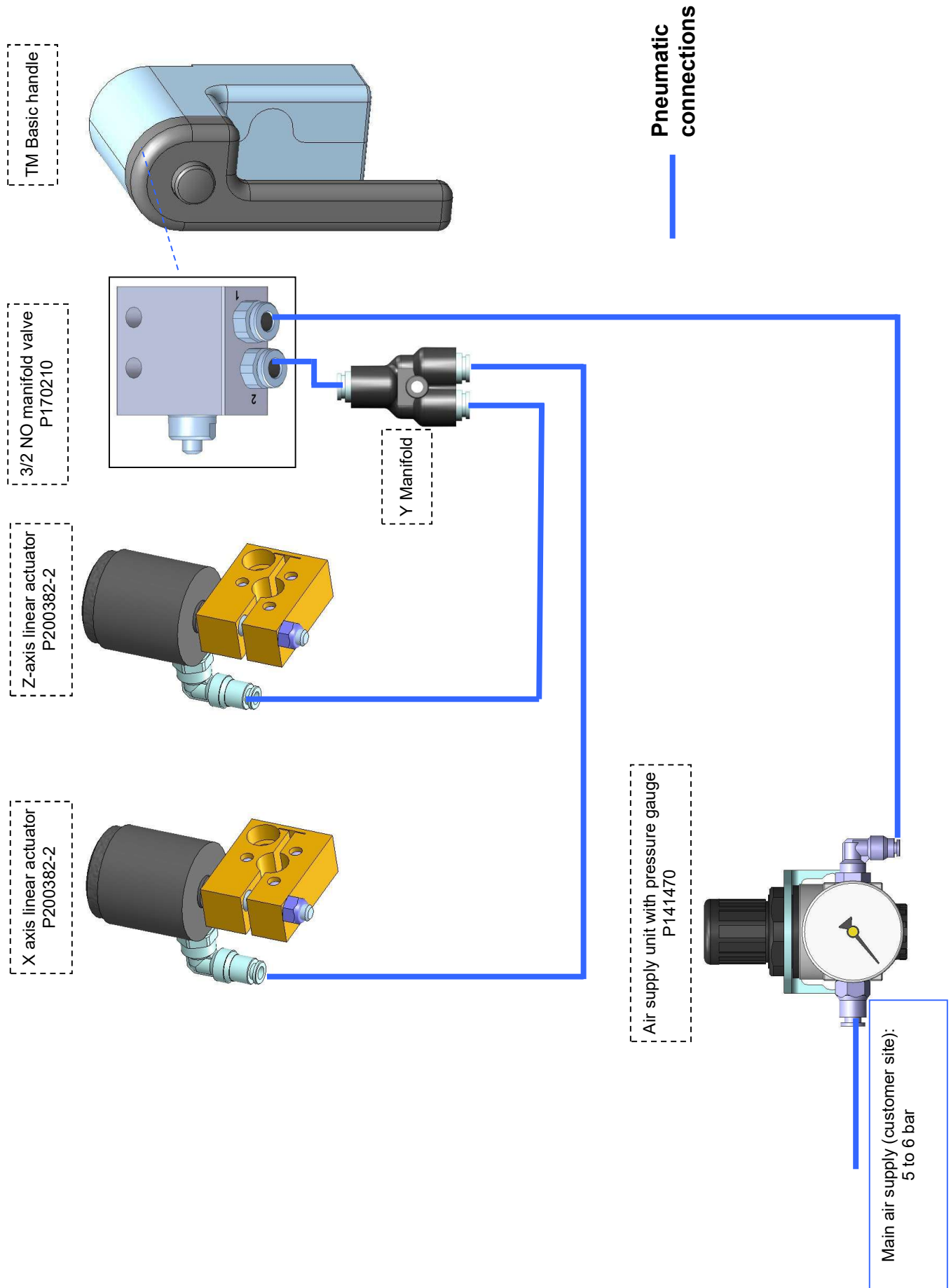

7.4.2 Tool ring: KV spindle

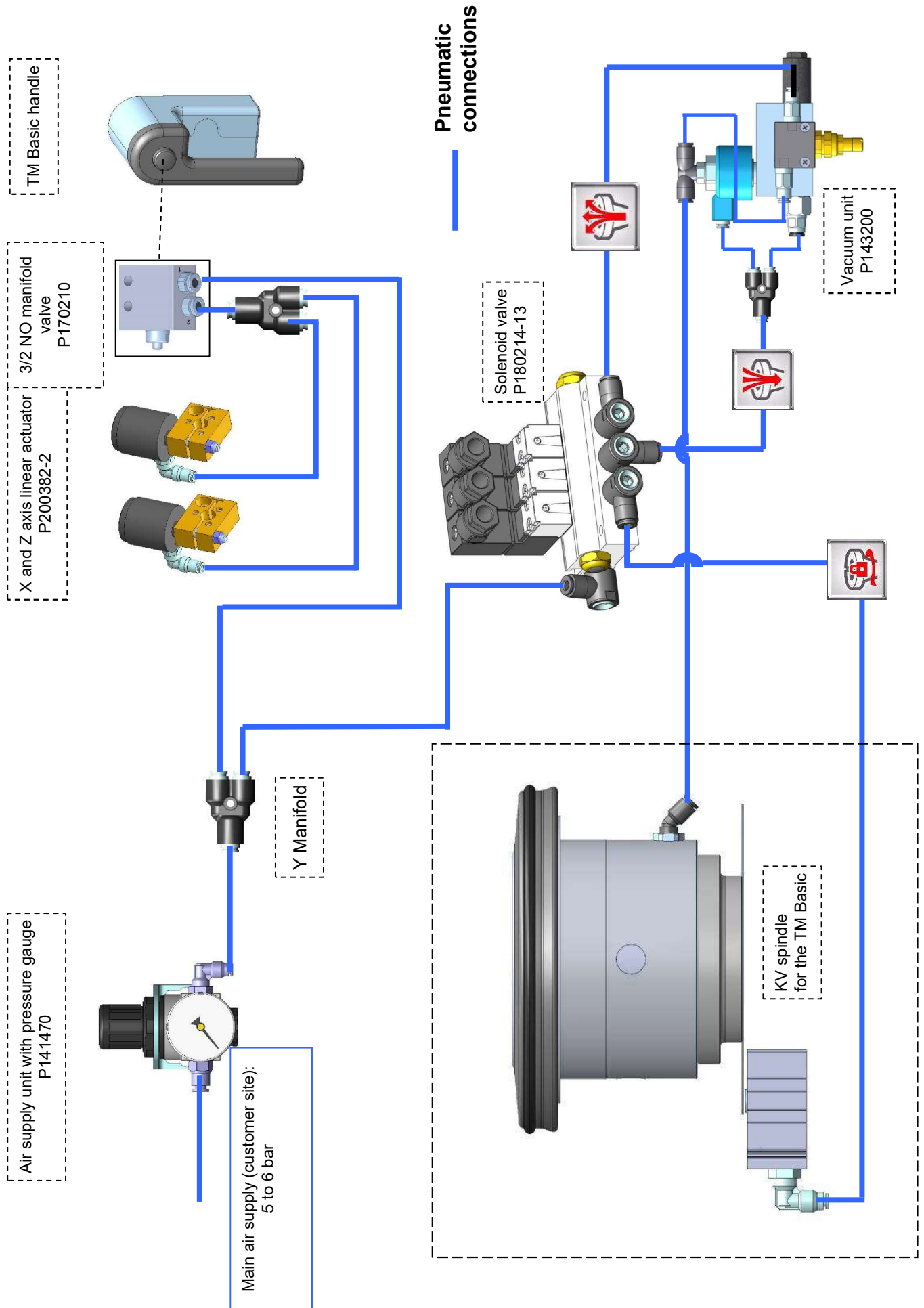

8 Declaration of conformity

KONFORMITÄTSERKLÄRUNG
DECLARATION OF CONFORMITY
DÉCLARATION DE CONFORMITÉ



Evoset AG

Besche Mattenstrasse 1
CH-3940 Steg
☎ +41 27 922 04 50



erklärt, dass das **Werkzeugvoreinstellgerät**:
*declares that the **tool presetter**:*
*déclare que le **banc de préréglage** :*

SERIEN-NR.:
SERIAL NUMBER:
N° DE SÉRIE :

MODELL:
MODEL:
MODÈLE :

TOOL MASTER Basic

MARKE:
BRAND:
MARQUE :

PWB

mit folgenden Richtlinien übereinstimmt:
are in accordance with the following directives:
est conforme aux directives suivantes :

RICHTLINIEN:
DIRECTIVES:
DIRECTIVES :

2006 / 42 / CE
2004 / 108 / CE
2006 / 95 / CE

NORMEN:
STANDARDS:
NORMES :

EN 61326-1:2006

Evoset AG

Stevan Vukicevic
Technical Director
Steg, 02.03.2022