

**EVOSET OFFERS
NOT ONLY SERVICE,
BUT RESULTS!**



EVOSET

...for best measuring results



PWB TOOL MASTER

The absolutely precise and most efficient solution for professional setting, measuring, testing, shrinking and management of tools.

TOOL MASTER

The finest high-precision
Swiss-built presetting
& shrinking systems
lead you to success

The PWB TOOL MASTER Modular System provides a professional solution for setting and measuring tools.

The TOOL MASTER is easy, fast, safe, precise, and delivers highly accurate results. With the TOOL MASTER, you can greatly improve the efficiency and profitability of your tool-setting and machinery operations.

We guarantee you higher quality, enhanced safety, increased speed, improved process reliability and less machine downtime.



- 4 TOOL MASTER
- 10 OPTIONS
- 12 SOFTWARE
- 13 DATA TRANSFER
- 14 TOOL SHRINK
- 18 TOOL BOY
- 19 SERVICE & AFTER SALES
- 20 EVOSSET

TOOL MASTER

BASIC

The unbeatable and efficient entry-level solution for exact measurements of tools.

Equipped with all necessary measurement functions.



FEATURES

- Plug & Play solution
- Manual control in X | Z | C
- EyeRay® Basic image Processing
- CMOS digital camera with telecentric lens
- PWB desktop PC solution with 18.5" monitor
- Integrated ISO50 or ISO40 tool spindle
- Pneumatic clamping in X and Z
- Endless manual fine adjustment
- Fast focusing of the tool cutting edge
- Tool inspection in transmitted and reflected light
- EyeRay® interface
- Online support interface
- Multi-lingual measuring software EyeRay®
- Highest concentricity & highest measuring repeatability thanks to the EVOSET high precision spindle needle bearing
- High axial radial runout accuracy needle bearing from $< 2\mu$; vacuum spindle KV from $< 2\mu$
- Operating system Windows 10
- Electrical voltage 230 Volt

OPTIONAL

- Cabinet with adapter tray for tools
- Master mandrel, small
- Thermal printer incl. 1 roll of labels
- Indexing device for turning tools
- Mechanical spindle brake
- Vacuum clamping with pneumatic spindle brake
- Data transfer through post-processor, RFID data carrier (Balluff), QR code, customer's specialized solutions

MEASUREMENT RANGE

X=400 Z=400

X=400 Z=600

TOOL MASTER

QUADRA

The TOOL MASTER Quadra guarantees: fast, easy and high-precision tool setting & measuring for all production requirements.

The professional and compact solution for higher quality, optimization of production processes and flexibility.



FEATURES

- Manual control in X | Z and C
- EyeRay® Quadra image processing
- CMOS digital camera with telecentric lens
- All in One PC 22" with touch screen
- Measuring system with glass scales
- Endless manual fine adjustment
- Integrated ISO50 or ISO40 tool spindle
- Pneumatic clamping in X and Z
- Spindle clamping
- Tool inspection in transmitted and reflected light
- Cabinet with integrated tool spindle tray for tools
- Thermal printer incl. 1 roll of labels
- Adapter and tool management
- EyeRay® Interface
- Online Support Interface
- Operator management
- Multi-lingual measuring software EyeRay®
- Highest concentricity & highest measuring repeatability thanks to the EVOSET high precision spindle needle bearing
- High axial radial runout accuracy needle bearing from $< 2\mu$; vacuum spindle KV from $< 2\mu$
- Plug-in connector with adapter EU/CH
- Operating system Windows 10
- Electrical voltage 230 Volt

OPTIONAL

- Measuring field shift in X and Z axis
- Pneumatic selective clamping in X and Z
- Data transfer through post-processor, RFID data carrier (Balluff), QR code, customer's specialized solutions
- Two-camera systems
- Indexing device for turning tools
- Vacuum clamping with pneumatic Spindle brake

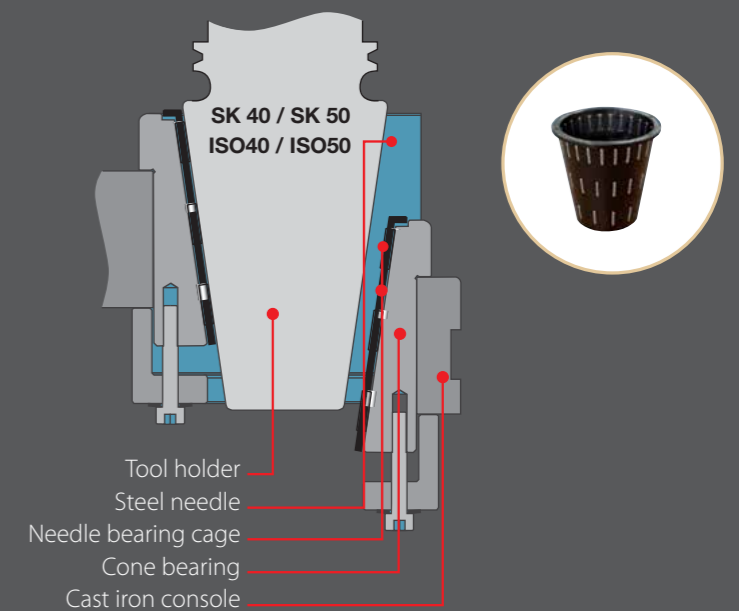
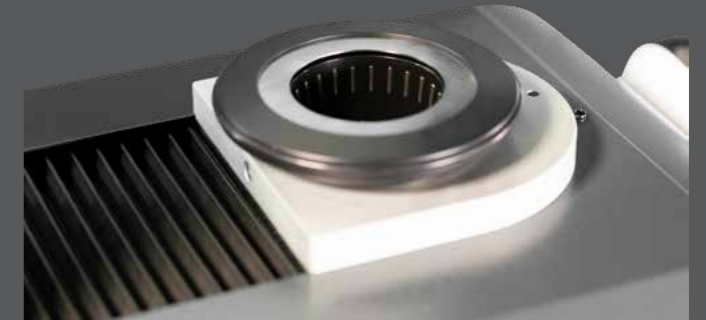

MEASUREMENT RANGE

X=400 Z=400	X=600 Z=400
X=400 Z=600	X=600 Z=600

On request: measuring ranges up to Z=760 mm

TOOL MASTER

5



With TOOL MASTER 5, you can measure tools with the highest demands. We guarantee proven highly accurate measurement results and highly efficient measuring process.

FEATURES

- Joystick & Touch control in X | Z axes
- EyeRay® TM5 image processing
- CMOS digital camera with telecentric lens
- All in One PC 22" with touch screen
- Measuring system with glass scales
- Endless automatic fine adjustment
- Integrated ISO50 or ISO40 tool spindle
- Spindle clamping
- Tool inspection in transmitted and reflected light
- Thermal printer incl. 1 roll of labels
- Adapter and tool management
- EyeRay® interface
- Online support interface
- Operator management
- Multi-lingual measuring software EyeRay®
- Highest concentricity & highest measuring repeatability thanks to the EVOSET high precision spindle needle bearing
- High axial radial runout accuracy needle bearing from <math>< 2\mu</math>
- Plug-in connector with adapter EU/CH
- Operating system Windows 10
- Electrical voltage 230 Volt

OPTIONAL

- Data transfer through post-processor, RFID data carrier, customer's specialized solutions
- Cabinet
- Indexing equipment for turning tools
- Vacuum clamping with pneumatic spindle brake

MEASUREMENT RANGE

X=400/600/1000 Z=600/900

SOFTWARE

With EyeRay® you are ahead worldwide

The EYERAY® software is reliable, easy to operate, modular and expandable – a world leader.

EyeRay® with its collection of software modules is a comprehensive and professional application for tool presetting, measurement and evaluation.

All PWB TOOL MASTER devices are equipped with

EyeRay® for simple and complex measuring tasks and guarantees a solution for every requirement.

- Easy to operate with only six basic icons
- Self-explanatory functional keys
- Expandable and upgradeable for any special measurement functions and requirements
- Quick measurements thanks to favorite shortcuts
- Fully automated operation
- Connection interfaces to all possible machine controls and manufacturing processes
- Guaranteed process reliability
- Consistently precise measurement results



DATA TRANSFER

Basis for conventional or modern manufacturing - optimized production processes from tool management, CAD/CAM to setting, measuring and shrinking of tools.

EVOSET offers a range of interfaces to CAM systems as well as to all various machine controls. The data transfer and communication between

the various systems is simple, secure and quick.

In modern manufacturing, the tool data is the basis of all production processes- from the CAD/CAM system through setting and measuring to the production of the workpiece.



DATA TRANSFER POSSIBILITIES

- Post-processor
- RFID data carrier (Balluff)
- QR CODE with scanning
- Data Matrix code
- USB stick or serial interface
- Label printing
- Customized connections

OPTIONS

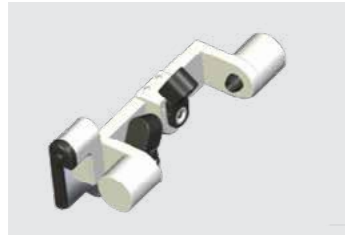

CHC / Center Height Camera
Height measuring of turning tools

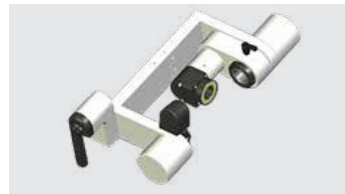

VHC / Vertical -Horizontal Camera
Measuring in horizontal and vertical directions. The camera is horizontally and vertically adjustable with any intermediate angles – this allows measuring of cutting angles and radii



LED ring light



Inspection/front light



Indexing equipment for rotary tools

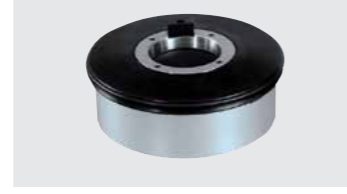

Vacuum spindle



Tool tray

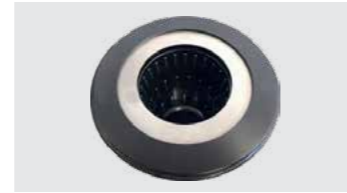

Needle bearing spindle with spindle brake



Printer



Master mandrel

- SK40 / SK50 : \varnothing 30 x 330
- SK40 / SK50 : \varnothing 30 x 90



Cabinet



Pneumatic selective clamping in X and Z

Measuring field variations

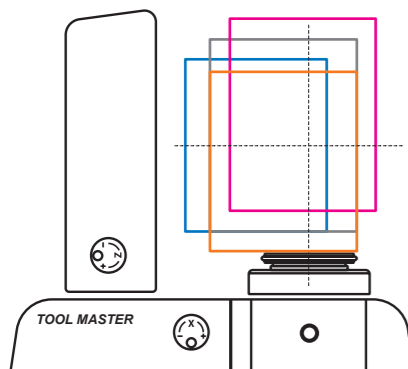

- X 1
- X 2 Standard (Z500)
- ZD 1 Standard (Z750)
- ZH 1

Clamping Inserts / Reductions / Adapters

SK

- Reduction SK/ISO to SK/ISO
In-house calibration ensures consistent quality
- Offset value is engraved on the reduction according to the following table

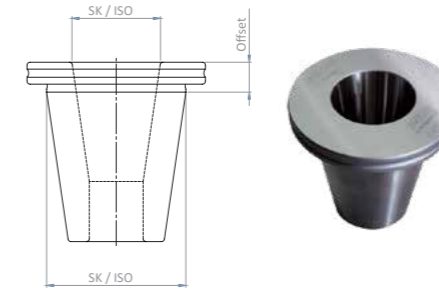

Internal shape	Offset value (Z)	
	SK50 / ISO50	SK40 / ISO40
SK10	30 mm	30 mm
SK15	30 mm	30 mm
SK20	15 mm	15 mm
SK25	15 mm	15 mm
SK30	15 mm	15 mm
SK35	15 mm	15 mm
SK40	15 mm	-
SK45	15 mm	-

HSK (shapes A to F)

- Reduction SK/ISO to HSK, available with and without clamping attachment
- Offset value is engraved on the reduction according to the following table

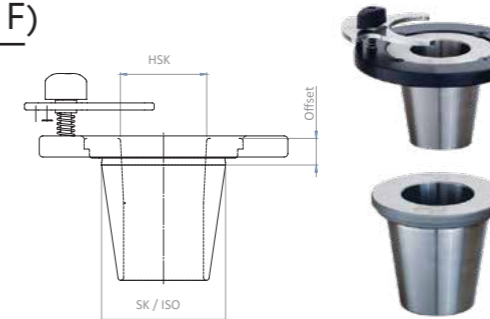

Internal shape	Offset value (Z)	
	SK50 / ISO50	SK40 / ISO40
HSK-A25	15 mm	15 mm
HSK-A32	15 mm	15 mm
HSK-A40	15 mm	15 mm
HSK-A50	15 mm	15 mm
HSK-A63	15 mm	60 mm
HSK-A80	52 mm	-
HSK-A100	70 mm	-

VDI with clamp lever

- Clamping of the VDI tool holder with clamping lever
- Clearance provided in the reduction for O-ring of the VDI shank

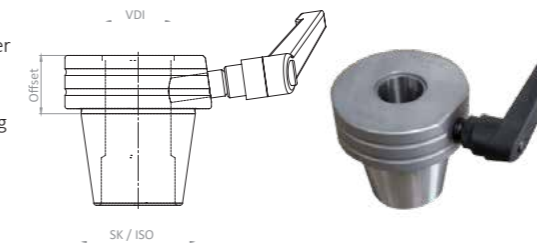

Internal shape	Offset value (Z)	
	SK50 / ISO50	SK40 / ISO40
VDI16	50 mm	50 mm
VDI20	35 mm	35 mm
VDI25	35 mm	35 mm
VDI30	35 mm	35 mm
VDI40	35 mm	70 mm
VDI50	35 mm	90 mm
VDI60	100 mm	-

VDI with index

- 4x90° indexing on reduction. VDI tool holder is aligned in reduction by means of centring pins
- Clearance provided in reduction for O-ring of the VDI shank

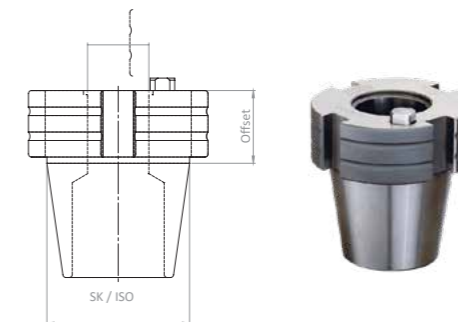

Internal shape	Offset value (Z)	
	SK50 / ISO50	SK40 / ISO40
VDI16	50 mm	50 mm
VDI20	35 mm	35 mm
VDI25	35 mm	35 mm
VDI30	35 mm	35 mm
VDI40	35 mm	80 mm
VDI50	35 mm	-
VDI60	100 mm	-
VDI80	140 mm	-

Capto ,Easy'

- Capto tool holder is centred using the 3 highest points of the polygon in the reduction, fixed with clamping claw

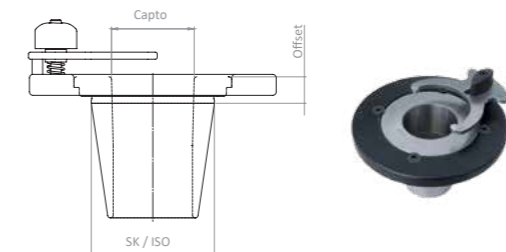

Internal shape	Offset value (Z)	
	SK50 / ISO50	SK40 / ISO40
C3	15 mm	-
C4	15 mm	-
C5	15 mm	-
C6	15 mm	-
C8	52 mm	-
C10	80 mm	-

TOOL SHRINK

BASIC

TOOL SHRINK Basic is the leading developed entry-shrink technology for speed, safety and flexibility for tool-holders.



FEATURES

- Smart-coil solution (measures the resistance of the holder thickness) Low/optimized power consumption by automatic adjusting kw & heating time for each holder
- Power consumption 7- 15kw; no overheating
- Fast shrinking and unclamping of ALL tool-holders from \varnothing 3 – 32 mm (40 mm as well with the same coil) in HSS, heavy metals / carbide and MST; magnetic & non-magnetic tool-holders
- Keypanel-Easy
- Long lifetime of the tool holders due to automatic shrinking cycles
- High concentricity
- Ergonomic design for enhanced safety during use
- Reduced setup costs and downtime on tool replacement
- Shrink time approx. 2-7 seconds (depending on tool-holder shape)
- Web-interface 4.0
- EVO Pi-interface (individual shrink cycles & for special/customized applications)
- Online support interface
- Air pressure connection from 3 to 6 bar
- Max. shrinking length: 430 to 490mm
- Max. machine interface: HSK-A125

DELIVERY CONTENT

- Multi-function adapters for SK|BT|CAT 40 & 50; HSK 63|100; C6
- Smart coil with interchangeable stop discs
- Fans
- Protecting cone
- Pair of gloves
- Pi-Interface 4.0
- Online support interface

OPTIONAL & ACCESSORIES

- Air-power cooling
- Water cooling unit complete (EU/US)
2 Cooling collars
Extension table for the cooling collars and bushes
Connection directly to the TOOL SHRINK EVO (EU) or separately (US)
Accessories: cooling adapters
- Adapter positioning rings for SK|BT|CAT 30 & C3|C5|C8
- Tool-holder air-cooling-box
- Easy-height
- Cabinet



Cabinet



Water-cooling



Air-cooling-box

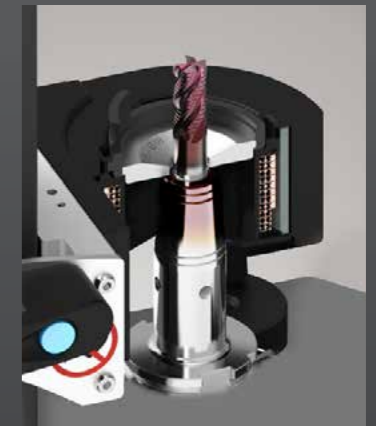

Smart-coil EVO



Air-power cooling

TOOL SHRINK

EVO

TOOL SHRINK EVO the most efficient shrink tool for speed, safety and flexibility for HSS and carbide tools- with individual and customized heating programs.



SPEED

- Shrink time approx. 2- 7 seconds (depending on tool diameter)
- Cooling time 40+ seconds (depending on tool diameter)
- Fast operation with keypanel-easy

FLEXIBLE

- Fast shrinking and unclamping of ALL tools from Ø 3- 32 mm in HSS, heavy metals or carbide
- Individual shrink cycles (also for special applications) are created via EVO Pi interface and added to the programs

SAFETY AND ADVANTAGES

- Tool holders have a long service life due to automated shrink cycles
- Smart inductor – automatic heating cycles prevent overheating and reduce energy usage
- High concentricity
- Reduced setup costs and downtime during tool change
- Ergonomic design for enhanced safety during use



TECHNICAL DATA - OPTIMA SHRINK EVO

POWER CONSUMPTION	7-15 kW
DIAMETER RANGE	For all tools from Ø 3 to 32 mm
SHRINK TIME	2- 7 seconds (depending on tool diameter)
MAX SHRINK LENGTH	430 to 490 mm
MAX MACHINE INTERFACE	HSK-A125
DIMENSIONS	317 x 943 x 920 mm (B x T x H)
WEIGHT	50 kg
DELIVERY CONTENT	8 Tool height adjustment stop rods 5 standard heat focusing stoppers 2 Cooling cones 1 Pair of Gloves 1 Pair of Pliers EVO Pi-Interface Online Support Interface 2.50 m Power Cable
ACCESSORIES	Cooling adapters SK HSK Capto
CONNECTIONS	<p>EU AC 3 Phase 400 V (+/-10%) + PE/23.8 A/50-60 Hz AC 3 Phase 400 V (+/-10%) + PE + N/23.8 A/50-60 Hz</p> <p>US AC 3 Phase 440-480 V + GND /23.8 A/50-60 Hz</p> <p>For other voltage supply a transformer is required (transformer ordered separately)</p> <p>Input voltage: 3 x 208 / 240 / 480 / 600 VAC + GND/28 A/50-60 Hz Output voltage: AC 3 x 400 V + PE + N/28 A/50-60 Hz</p> <p>Air pressure: 3 to 6 bar / hose diameter 10 mm required</p>

TECHNICAL DATA COOLING UNIT (optional)

COOLING TIME	40+ seconds (depending on tool diameter and cooling method)
EXTENSION TABLE	Storage of Cooling collars and adapters
DIMENSIONS	314 x 630 x 285 mm (W x D x H)
WEIGHT	35 kg
DELIVERY CONTENT	Cooling unit 2 Cooling collars Extension table Accessories: Cooling bush
CONNECTIONS	EU- Directly into the specific plug on the shrink device US- The cooling unit is connected separately



TOOL

BOY

The broadly equipped and secure mounting device for tools with various adapters.

Rely on the original and best-selling mounting aid worldwide.

ADVANTAGES

- Safer and faster change of toolholding systems
- Accident-free and ergonomic working
- 8 x 45° indexable, assembly of tools without reclamping
- Suitable for all tool systems
- Best tool protection through DELRIN inserts
- No effort due to optimum ergonomics



DIN 69871/DIN 2080
JIS B 6339 (MAS-BT)
ANSI CATV-Flange
Nr.
ISO 30 400520
ISO 35 400524
ISO 40 400521
ISO 45 400525
ISO 50 400522



DIN 69893
HSK - (Form A- F)
Nr.
HSK-A32 400544
HSK-A40 400545
HSK-A50 400540
HSK-A63 400541
HSK-A80 400542



DIN 69880
VDI 3425
Nr.
VDI 20 400580
VDI 25 400585
VDI 30 400581
VDI 40 400582
VDI 50 400583



KENNAMETAL
Widia / Tizit
Nr.
KM 32 400553
KM 40 400550
KM 50 400551
KM 63 400552



SANDVIK
Capto
Nr.
Capto C3 400135
Capto C4 400136
Capto C5 400137
Capto C6 400138
Capto C8 400139

SERVICE & AFTER SALES

We offer you a comprehensive service to achieve and maintain maximum efficiency of production.

Our service team supports you for your individual requirements, installation and product training- with EVOSET you have not only high precision products but also highly professional assistance and broad manufacturing knowledge.

ADDED VALUE

- Customer service, refer to local agent or service@evoaset.com
- Remote maintenance (online support)- for any kind of software problem or for quick support
- Software updates for new or optimized functions
- Conversion, upgrade and retro fit kits for all devices
- Additional data connections and interfaces
- Individual customization of software & data entry of software
- Spare parts & accessories

To avail the best use of EVOSET PRODUCTS our excellently trained staff offers professional consulting,, commissioning and product training.



SERVICE - THE TRUE MEASURE OF VALUE



EVOSET

SWISS INNOVATION FOR THE WHOLE WORLD



The focus of the product lines in the optimal realization of the individual customer needs. EVOSET pursues intelligent and complementary solutions in the area of tool presetting management, measurement, inspection and shrinking.

We have experience with our own developments of devices and software. Our engineering staff guarantees know-how, success and efficiency for your product- we increase your productivity.

In addition to the strong product development and production, we offer a worldwide professional service in time to our customers.

As a partner of the manufacturing industry EVOSET continuously develops new Swiss quality products to further optimize the processes of the industry.

Your satisfaction and your success is our highest priority.

EVOSET is the world leader in tool presetting, measuring and shrinking.

We combine productivity with absolute user-friendliness and offer tailor-made solutions for individual project requirements, through to complete solutions in the area of tool management and connection to all manufacturing processes.

QUALITY AND RESPONSIBILITY

EVOSET stands for world-class «MADE IN SWITZERLAND»

The success of our customers and partners demonstrates the importance of innovation and sustainable thinking, high quality implementation taking in to consideration cost efficiency and sustainability.

Our products are built to be energy-efficient and environmentally friendly.

Our technologies and methods not only benefit the environment, but they also help our customers to save money.

Our mindset is reflected in our remarkable international reputation EVO SET stands for world-class «MADE IN SWITZERLAND»

SOCIAL RESPONSIBILITY

Our foundation is built on trustworthy relationships and fair dealings with employees, customers, suppliers, and the general public.

EVOSET defines social responsibility in three areas

THE PEOPLE
KNOWLEDGE
THE CHANGE

Our main focus is the human beings
We share our knowledge of manufacturing processes.
Together we are breaking new grounds in innovation

EVOSET stands up for responsibility, conducting business ethically and ecologically, whilst still being economical and socially responsible

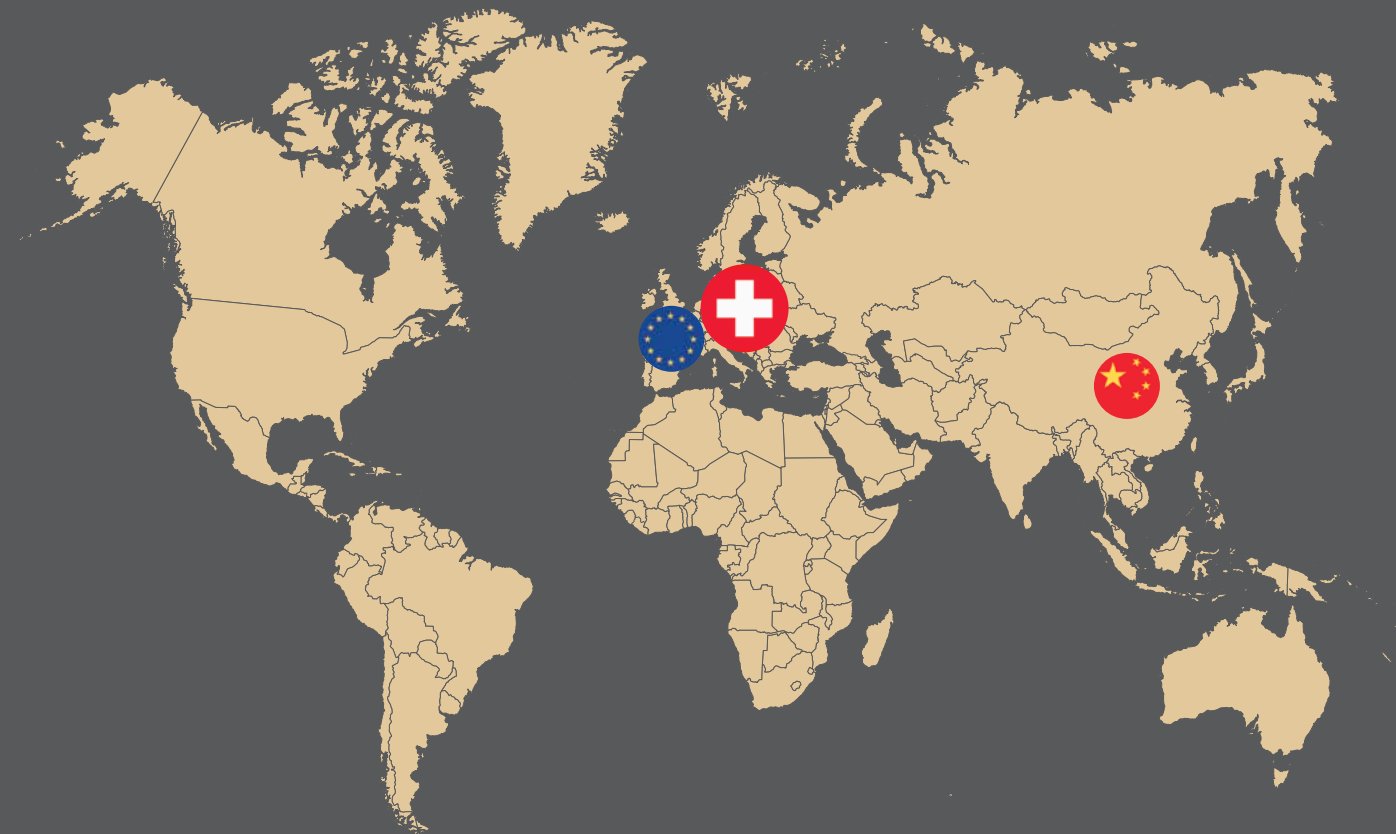

Headquarter & Production facility



Technical office



Technical office

EVOSET AG

Alustrasse 18
3940 Steg
Switzerland

Hüttenwiesenstrasse 8
8108 Dällikon
Switzerland

Fon +41 27 922 04 50
info@evoaset.com

www.evoaset.com

EVOSET (EU) CTI

447 , rue des Trois Fontaines
13123 Arles, France
Fon +33 4 90 96 83 33

EVOSET (Asia) China

PWB (BEIJING) Instr. Co., Ltd.
No. 2620, Enterprise
Development service center, Xiji Town, Tongzhou District
Beijing, 101106, China
Fon +86 13911076044